

## APXVBLL15B\_43-C-I20 APXVBLL15B\_43-A-I20

### Features

- 2 ports / 1 cross pol system in low band (698-960 MHz)
- 4 ports / 2 cross pol systems in high band (1710-2690 MHz)
- Supporting 4x4 MIMO in high band
- Integrated and field replaceable SRET
- ACU HW version -2.02
- Optional with Direct Pipe No Tilt mounting hardware (Model name suffix -A-I20)
- Compliant with AISG v2.0 and 3GPP



PRODUCT OVERVIEW	Frequency Range (MHz)	(1x) 698-960	(2x) 1710-2690	
	Array	■ R1	■ Y1	■ Y2
	Connector	1-2	3-4	5-6
		6 PORTS		
	Polarization	XPOL		
	Azimuth Beamwidth (avg)	65°	65°	65°
	Electrical Downtilt	2-15°	2-11°	
	Dimensions	1500 x 350 x 200 mm (59.1 x 13.8 x 7.9 in)		

### ORDERING OPTIONS

Select from the following ordering options

ANTENNA MODEL NUMBER	CONFIGURATION	MOUNTING HARDWARE	MOUNTING PIPE DIAMETER	SHIPPING WEIGHT	MOUNTING HARDWARE WEIGHT
APXVBLL15B_43-C-I20	ACU-I20-B3 Internal Field Replaceable RET Included	APM50-B1 Beam Tilt Kit Included	50-110 mm (2.0-4.3 in)	29.0 kg (63.9 lbs)	4.5 kg (9.9 lbs)
APXVBLL15B_43-A-I20	ACU-I20-B3 Internal Field Replaceable RET Included	APM50-B1N Direct Pipe No Tilt Mounting Kit Included	50-110 mm (2.0-4.3 in)	27.9 kg (61.5 lbs)	3.4 kg (7.5 lbs)



Quoted performance parameters are provided to offer typical, peak or range values only and may vary as a result of normal testing, manufacturing and operational conditions. Extreme operational conditions and/or stress on structural supports is beyond our control. Such conditions may result in damage to this product. Improvements to products may be made without notice.

## APXVBLL15B\_43-C-I20

### APXVBLL15B\_43-A-I20

#### ELECTRICAL SPECIFICATIONS

■ R1

Frequency Range		MHz	698-960		
		MHz	698-806	790-894	880-960
Polarization		---	±45°		
Gain	Over all Tilts	dBi	14.1 ± 0.5	14.4 ± 0.8	14.8 ± 0.2
	Max Gain	dBi	14.6	15.2	15.0
Azimuth Beamwidth (3 dB)		degrees	66.7° ± 2.1°	65.8° ± 2.5°	64.6° ± 1.2°
Elevation Beamwidth (3 dB)		degrees	17.7° ± 1.6°	16.0° ± 0.9°	14.8° ± 0.7°
Electrical Downtilt		degrees	2-15°		
Impedance		Ohms	50Ω		
VSWR (Return Loss)		---	1.5:1 (-14 dB)		
Passive Intermodulation		dBc	-153 (3rd Order for 2x20 W Carriers)		
Front-to-Back Ratio, Total Power, ± 30°		dB	24.0	24.1	23.1
First Upper Side Lobe		dB	16.3	16.4	13.8
Cross-Pol Over Sector		dB	10.2	9.2	10.0
Cross Polar Discrimination (XPD) at Mechanical Boresight (0°)		dB	24.7	24.0	21.7
Maximum Effective Power Per Port		Watts	350 W		
Cross Polar Isolation		dB	26		
Interband Isolation		dB	26		

#### ELECTRICAL SPECIFICATIONS

■ Y1

Frequency Range		MHz	1710-2690				
		MHz	1710-1880	1850-1990	1920-2170	2300-2400	2490-2690
Polarization		---	±45°				
Gain	Over all Tilts	dBi	16.0 ± 0.7	16.8 ± 0.4	17.0 ± 0.4	16.5 ± 1.0	16.9 ± 0.6
	Max Gain	dBi	16.7	17.2	17.4	17.5	17.5
Azimuth Beamwidth (3 dB)		degrees	65.9° ± 5.5°	65.1° ± 4.3°	63.2° ± 6.7°	66.6° ± 4.9°	61.1° ± 3.2°
Elevation Beamwidth (3 dB)		degrees	6.8° ± 0.5°	6.3° ± 0.4°	5.9° ± 0.6°	5.2° ± 0.4°	4.7° ± 0.4°
Electrical Downtilt		degrees	2-11°				
Impedance		Ohms	50Ω				
VSWR (Return Loss)		---	1.5:1 (-14 dB)				
Passive Intermodulation		dBc	-153 (3rd Order for 2x20 W Carriers)				
Front-to-Back Ratio, Total Power, ± 30°		dB	19.3	21.1	22.7	22.3	21.5
First Upper Side Lobe		dB	16.2	15.5	16.4	15.9	14.9
Cross-Pol Over Sector		dB	9.2	9.5	8.8	8.9	5.4
Cross Polar Discrimination (XPD) at Mechanical Boresight (0°)		dB	26.9	26.1	24.6	16.1	17.5
Maximum Effective Power Per Port		Watts	250 W				
Cross Polar Isolation		dB	26				
Interband Isolation		dB	26				

Quoted performance parameters are provided to offer typical, peak or range values only and may vary as a result of normal testing, manufacturing and operational conditions. Extreme operational conditions and/or stress on structural supports is beyond our control. Such conditions may result in damage to this product. Improvements to products may be made without notice.

## APXVBLL15B\_43-C-I20

### APXVBLL15B\_43-A-I20

#### ELECTRICAL SPECIFICATIONS

■ Y2

Frequency Range		MHz	1710-2690				
		MHz	1710-1880	1850-1990	1920-2170	2300-2400	2490-2690
Polarization		---	±45°				
Gain	Over all Tilts	dBi	16.0 ± 0.6	16.8 ± 0.3	17.0 ± 0.4	16.4 ± 0.8	17.0 ± 0.7
	Max Gain	dBi	16.6	17.1	17.4	17.2	17.7
Azimuth Beamwidth (3 dB)		degrees	66.0° ± 5.1°	66.5° ± 4.7°	64.5° ± 6.9°	67.4° ± 5.2°	60.8° ± 2.5°
Elevation Beamwidth (3 dB)		degrees	6.7° ± 0.5°	6.2° ± 0.4°	5.9° ± 0.6°	5.1° ± 0.4°	4.7° ± 0.4°
Electrical Downtilt		degrees	2-11°				
Impedance		Ohms	50Ω				
VSWR (Return Loss)		---	1.5:1 (-14 dB)				
Passive Intermodulation		dBc	-153 (3rd Order for 2x20 W Carriers)				
Front-to-Back Ratio, Total Power, ± 30°		dB	20.9	20.0	20.3	22.4	22.9
First Upper Side Lobe		dB	16.2	16.1	17.3	16.5	14.9
Cross-Pol Over Sector		dB	7.7	8.2	7.5	8.9	5.7
Cross Polar Discrimination (XPD) at Mechanical Boresight (0°)		dB	20.6	19.2	20.7	14.7	15.5
Maximum Effective Power Per Port		Watts	250 W				
Cross Polar Isolation		dB	26				
Interband Isolation		dB	26				

Quoted performance parameters are provided to offer typical, peak or range values only and may vary as a result of normal testing, manufacturing and operational conditions. Extreme operational conditions and/or stress on structural supports is beyond our control. Such conditions may result in damage to this product. Improvements to products may be made without notice.

## APXVBLL15B\_43-C-I20 APXVBLL15B\_43-A-I20

### BOTTOM VIEW - LABELING



### ARRAY LAYOUT

ARRAY	FREQUENCY	CONNECTOR	CONNECTOR TYPE	RET	AISG RET UID
<span style="color: red;">■</span> R1	698-960 MHz	1-2	(2x) 4.3-10 Female	R1	RFxxxxxxxxxx-R1
<span style="color: yellow;">■</span> Y1	1710-2690 MHz	3-4	(2x) 4.3-10 Female	Y1	RFxxxxxxxxxx-Y1
<span style="color: yellow;">■</span> Y2	1710-2690 MHz	5-6	(2x) 4.3-10 Female		

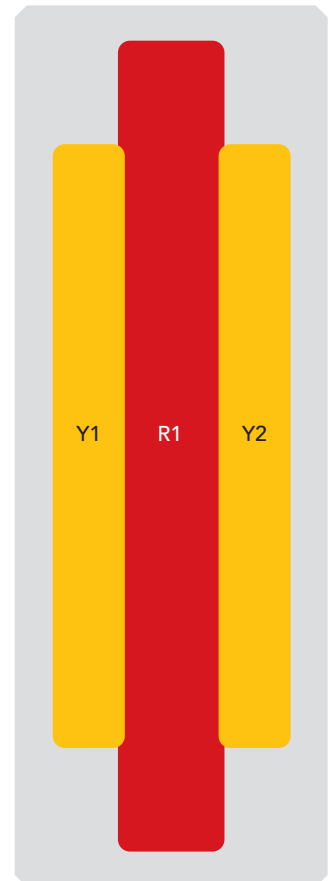

The illustration is not shown to scale.

Quoted performance parameters are provided to offer typical, peak or range values only and may vary as a result of normal testing, manufacturing and operational conditions. Extreme operational conditions and/or stress on structural supports is beyond our control. Such conditions may result in damage to this product. Improvements to products may be made without notice.

## APXVBLL15B\_43-C-I20

### APXVBLL15B\_43-A-I20

#### MECHANICAL SPECIFICATIONS

Length	mm (in)	1500 (59.1)
Width	mm (in)	350 (13.8)
Depth	mm (in)	200 (7.9)
Net Weight - Antenna Only	kg (lbs)	18.5 (40.8)
Wind Load Rated at 150 km/h (93 mph)	Front	N (lbf) 671 (151)
	Side	N (lbf) 330 (74)
	Rear	N (lbf) 385 (87)
Survival Wind Speed	km/h (mph)	200 (124)
Connector Type	--	(6x) 4.3-10 Female, (2x) AISG Connectors (1 Male, 1 Female) at Bottom
Radome Color	---	Light Grey RAL7035
Radome Material	---	Fiberglass
Lightning Protection	---	DC Ground
<b>Shipping</b>	Packing Size (Length x Width x Depth)	mm (in) 1750 x 445 x 295 (68.9 x 17.5 x 11.6)

#### ENVIRONMENTAL SPECIFICATIONS

Environmental Standard	---	ETS 300 019
Operating Temperature	degrees	-40° to +60° C (-40° to +140° F)
Product Environmental Compliance	---	Product is RoHS Compliant

## APXVBLL15B\_43-C-I20

### APXVBLL15B\_43-A-I20

#### ACCESSORIES

Accessories may be ordered separately unless otherwise indicated.

ITEM	MODEL NUMBER	WEIGHT
Beam Tilt Mounting Bracket Kit for Pole Diameter 50-110 mm (2.0-4.3 in) <i>Refer to ordering options</i>	APM50-B1	4.5 kg (9.9 lbs)
Direct Pipe No Tilt Bracket Kit for Pole Diameter 50-110 mm (2.0-4.3 in) <i>Refer to ordering options</i>	APM50-B1N	3.4 kg (7.5 lbs)

#### INSTALLATION

Please read all installation notes before installing product.



Always attach the antenna using all mounting points.

Do not install antenna with the connectors facing upwards.

#### EXTERNAL DOCUMENT LINKS

[APM50 Mounting Kit Series Installation Instructions](#)

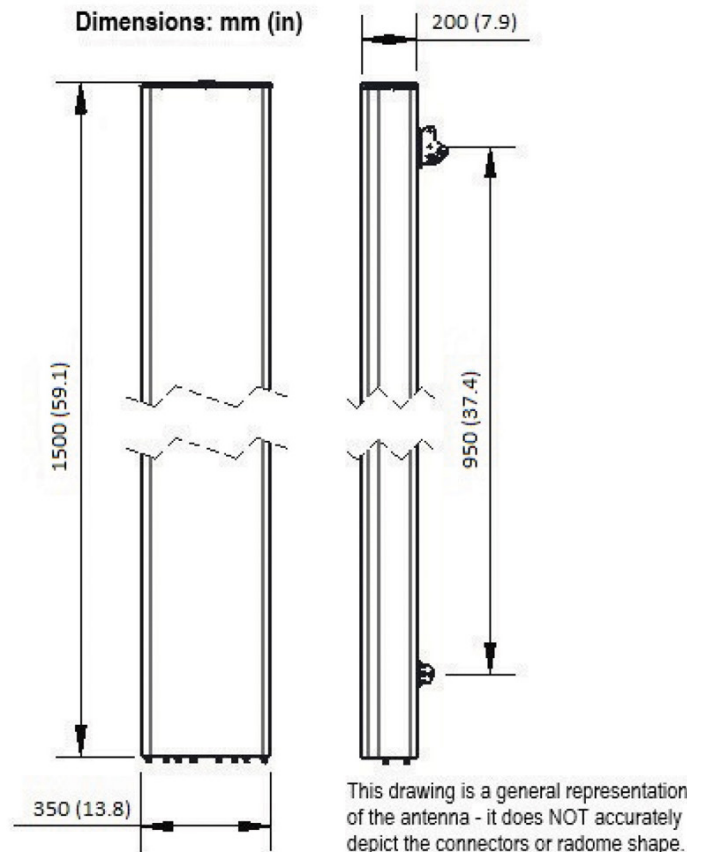

#### NOTES

Specifications follow BASTA guidelines.

For additional mounting information, please check **External Document Links**.

For Radiating Patterns: [Request pattern files](#)