

APXVBBLL20B_43-C-I20 APXVBBLL20B_43-A-I20

Features

- 4 ports / 2 cross pol systems in low band (698-960 MHz)
- 4 ports / 2 cross pol systems in high band (1710-2690 MHz)
- Supporting 4x4 MIMO
- Integrated and field replaceable SRET
- ACU HW version: 2.02
- Optional with Direct Pipe No Tilt mounting hardware (Model name suffix -A-I20)
- Compliant with AISG v2.0 and 3GPP



PRODUCT OVERVIEW	Frequency Range (MHz)	(2x) 698-960		(2x) 1710-2690	
	Array	■ R1	■ R2	■ Y1	■ Y2
	Connector	1-2	3-4	5-6	7-8
		8 PORTS			
	Polarization	XPOL			
	Azimuth Beamwidth (avg)	65°		65°	
	Electrical Downtilt	2-12°		2-12°	
	Dimensions	2090 x 499 x 199 mm (82.3 x 19.6 x 7.8 in)			

ORDERING OPTIONS Select from the following ordering options

ANTENNA MODEL NUMBER	CONFIGURATION	MOUNTING HARDWARE	MOUNTING PIPE DIAMETER	SHIPPING WEIGHT	MOUNTING HARDWARE WEIGHT
APXVBBLL20B_43-C-I20	ACU-I20-B4 Internal RET Included	APM50-B1 Beam Tilt Kit Included	50-110 mm (2.0-4.3 in)	47.0 kg (103.6 lbs)	4.5 kg (9.9 lbs)
APXVBBLL20B_43-A-I20	ACU-I20-B4 Internal RET Included	APM50-B1N Direct Pipe No Tilt Mounting Kit Included	50-110 mm (2.0-4.3 in)	45.9 kg (101.2 lbs)	3.4 kg (7.5 lbs)



Quoted performance parameters are provided to offer typical, peak or range values only and may vary as a result of normal testing, manufacturing and operational conditions. Extreme operational conditions and/or stress on structural supports is beyond our control. Such conditions may result in damage to this product. Improvements to products may be made without notice.

APXVBBLL20B_43-C-I20

APXVBBLL20B_43-A-I20

ELECTRICAL SPECIFICATIONS

■ R1

Frequency Range		MHz	698-960		
		MHz	698-806	790-894	880-960
Polarization		---	±45°		
Gain	Over all Tilts	dBi	14.9 ± 1.1	16 ± 0.4	16.5 ± 0.2
	Max Gain	dBi	16.0	16.4	16.7
Azimuth Beamwidth (3 dB)		degrees	61° ± 8.6°	54.6° ± 6.3°	49.7° ± 6.1°
Elevation Beamwidth (3 dB)		degrees	10.3° ± 1.3°	9.1° ± 0.6°	8.2° ± 0.6°
Electrical Downtilt		degrees	2-12°		
Impedance		Ohms	50Ω		
VSWR (Return Loss)		---	1.5:1 (-14 dB)		
Passive Intermodulation 3rd Order for 2x20 W Carriers		dBc	-153		
Front-to-Back Ratio, Total Power, ± 30°		dB	19.5	22.5	21.4
First Upper Side Lobe Suppression		dB	11.3	11.3	10.8
Cross Polar Discrimination Over Sector		dB	7.7	10.3	9.9
Cross Polar Discrimination (XPD) at Mechanical Boresight (0°)		dB	19.3	19.4	18.6
Maximum Effective Power Per Port		Watts	350 W		
Cross Polar Isolation		dB	26		
Interband Isolation		dB	26		

Specifications follow BASTA guidelines.

ELECTRICAL SPECIFICATIONS

■ R2

Frequency Range		MHz	698-960		
		MHz	698-806	790-894	880-960
Polarization		---	±45°		
Gain	Over all Tilts	dBi	14.9 ± 1.2	16 ± 0.5	16.4 ± 0.3
	Max Gain	dBi	16.1	16.5	16.7
Azimuth Beamwidth (3 dB)		degrees	61.5° ± 7.3°	55.9° ± 6.7°	50.4° ± 7.1°
Elevation Beamwidth (3 dB)		degrees	10.3° ± 1.3°	9.1° ± 0.7°	8.2° ± 0.5°
Electrical Downtilt		degrees	2-12°		
Impedance		Ohms	50Ω		
VSWR (Return Loss)		---	1.5:1 (-14 dB)		
Passive Intermodulation 3rd Order for 2x20 W Carriers		dBc	-153		
Front-to-Back Ratio, Total Power, ± 30°		dB	20.6	21.4	20.9
First Upper Side Lobe Suppression		dB	11.4	11.4	11
Cross Polar Discrimination Over Sector		dB	8.1	9.2	9.1
Cross Polar Discrimination (XPD) at Mechanical Boresight (0°)		dB	18.9	19.6	22
Maximum Effective Power Per Port		Watts	350 W		
Cross Polar Isolation		dB	26		
Interband Isolation		dB	26		

Specifications follow BASTA guidelines.

Quoted performance parameters are provided to offer typical, peak or range values only and may vary as a result of normal testing, manufacturing and operational conditions. Extreme operational conditions and/or stress on structural supports is beyond our control. Such conditions may result in damage to this product. Improvements to products may be made without notice.

APXVBBLL20B_43-C-I20

APXVBBLL20B_43-A-I20

ELECTRICAL SPECIFICATIONS

■ Y1

Frequency Range		MHz	1710-2690				
		MHz	1710-1880	1850-1990	1920-2170	2300-2400	2490-2690
Polarization		---	±45°				
Gain	Over all Tilts	dBi	17.3 ± 0.5	17.7 ± 0.6	17.9 ± 0.7	18.1 ± 0.4	18.4 ± 0.6
	Max Gain	dBi	17.8	18.3	18.6	18.5	19.0
Azimuth Beamwidth (3 dB)		degrees	59.7° ± 6.5°	63.2° ± 7.3°	60.4° ± 11.8°	60.6° ± 8.9°	53.7° ± 5.3°
Elevation Beamwidth (3 dB)		degrees	5.4° ± 0.5°	4.9° ± 0.4°	4.6° ± 0.5°	4° ± 0.3°	3.8° ± 0.4°
Electrical Downtilt		degrees	2-12°				
Impedance		Ohms	50Ω				
VSWR (Return Loss)		---	1.5:1 (-14 dB)				
Passive Intermodulation 3rd Order for 2x20 W Carriers		dBc	-153				
Front-to-Back Ratio, Total Power, ± 30°		dB	22.6	24.5	23.4	20.8	21.2
First Upper Side Lobe Suppression		dB	16.3	16.2	15.8	16.3	15.2
Cross Polar Discrimination Over Sector		dB	8.4	5.7	5.1	1.6	1.1
Cross Polar Discrimination (XPD) at Mechanical Boresight (0°)		dB	15.8	17.3	14.1	15.1	19.2
Maximum Effective Power Per Port		Watts	250 W				
Cross Polar Isolation		dB	26				
Interband Isolation		dB	26				

Specifications follow BASTA guidelines.

ELECTRICAL SPECIFICATIONS

■ Y2

Frequency Range		MHz	1710-2690				
		MHz	1710-1880	1850-1990	1920-2170	2300-2400	2490-2690
Polarization		---	±45°				
Gain	Over all Tilts	dBi	17.1 ± 0.6	17.6 ± 0.6	17.7 ± 0.5	18 ± 0.5	18.2 ± 0.7
	Max Gain	dBi	17.7	18.2	18.2	18.5	18.9
Azimuth Beamwidth (3 dB)		degrees	61.4° ± 7.4°	62.3° ± 7°	60.3° ± 11°	63.5° ± 8.9°	55.3° ± 6°
Elevation Beamwidth (3 dB)		degrees	5.4° ± 0.5°	5° ± 0.3°	4.7° ± 0.5°	4.1° ± 0.4°	3.8° ± 0.4°
Electrical Downtilt		degrees	2-12°				
Impedance		Ohms	50Ω				
VSWR (Return Loss)		---	1.5:1 (-14 dB)				
Passive Intermodulation 3rd Order for 2x20 W Carriers		dBc	-153				
Front-to-Back Ratio, Total Power, ± 30°		dB	22.7	25	22.9	22.7	22.4
First Upper Side Lobe Suppression		dB	17	18.2	17.5	17.1	15.7
Cross Polar Discrimination Over Sector		dB	8.2	4.3	3.9	1.3	1.2
Cross Polar Discrimination (XPD) at Mechanical Boresight (0°)		dB	16	16.8	15	13.8	17.7
Maximum Effective Power Per Port		Watts	250 W				
Cross Polar Isolation		dB	26				
Interband Isolation		dB	26				

Specifications follow BASTA guidelines.

Quoted performance parameters are provided to offer typical, peak or range values only and may vary as a result of normal testing, manufacturing and operational conditions. Extreme operational conditions and/or stress on structural supports is beyond our control. Such conditions may result in damage to this product. Improvements to products may be made without notice.

APXVBBLL20B_43-C-I20 APXVBBLL20B_43-A-I20

BOTTOM VIEW - LABELING



ARRAY LAYOUT

ARRAY	FREQUENCY	CONNECTOR	CONNECTOR TYPE	RET	AISG RET UID
■ R1	698-960 MHz	1-2	(2x) 4.3-10 Female	R1	RFxxxxxxxxxx-R1
■ R2	698-960 MHz	3-4	(2x) 4.3-10 Female	R2	RFxxxxxxxxxx-R2
■ Y1	1710-2690 MHz	5-6	(2x) 4.3-10 Female	Y1	RFxxxxxxxxxx-Y1
■ Y2	1710-2690 MHz	7-8	(2x) 4.3-10 Female	Y2	RFxxxxxxxxxx-Y2

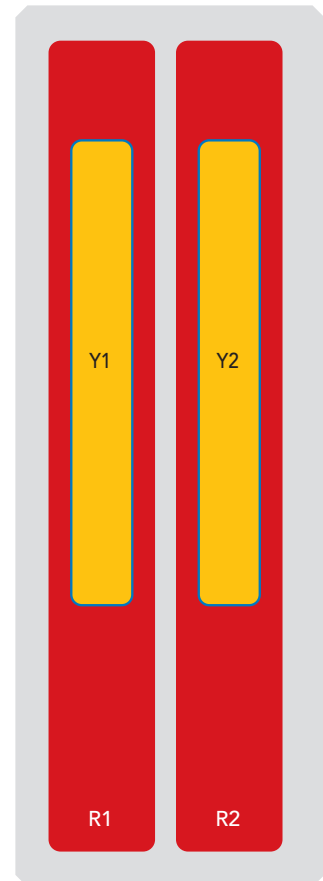

The illustration is not shown to scale.

Quoted performance parameters are provided to offer typical, peak or range values only and may vary as a result of normal testing, manufacturing and operational conditions. Extreme operational conditions and/or stress on structural supports is beyond our control. Such conditions may result in damage to this product. Improvements to products may be made without notice.

APXVBBLL20B_43-C-I20

APXVBBLL20B_43-A-I20

MECHANICAL SPECIFICATIONS

Length	mm (in)	2090 (82.3)
Width	mm (in)	499 (19.6)
Depth	mm (in)	199 (7.8)
Net Weight - Antenna Only	kg (lbs)	36 (79.4)
Wind Load Rated at 150 km/h (93 mph)	Front	N (lbf) 701 (158)
	Side	N (lbf) 557 (125)
	Rear	N (lbf) 833 (187)
Survival Wind Speed	km/h (mph)	200 (124)
Connector Type	--	(8x) 4.3-10 Female, (2x) AISG Connectors (1 Male, 1 Female) at Bottom
Radome Color	---	Light Grey RAL7035
Radome Material	---	Fiberglass
Lightning Protection	---	Direct Ground
Shipping	Packing Size (Length x Width x Depth)	mm (in) 2340 x 595 x 295 (92.1 x 23.4 x 11.6)

ENVIRONMENTAL SPECIFICATIONS

Environmental Standard	---	ETS 300 019
Operating Temperature	degrees	-40° to +60° C (-40° to +140° F)
Product Environmental Compliance	---	Product is RoHS Compliant

Quoted performance parameters are provided to offer typical, peak or range values only and may vary as a result of normal testing, manufacturing and operational conditions. Extreme operational conditions and/or stress on structural supports is beyond our control. Such conditions may result in damage to this product. Improvements to products may be made without notice.

APXVBBLL20B_43-C-I20

APXVBBLL20B_43-A-I20

ACCESSORIES

Accessories may be ordered separately unless otherwise indicated.

ITEM	MODEL NUMBER	WEIGHT
Beam Tilt Mounting Bracket Kit for Pole Diameter 50-110 mm (2.0-4.3 in) <i>Refer to ordering options</i>	APM50-B1	4.5 kg (9.9 lbs)
Direct Pipe No Tilt Bracket Kit for Pole Diameter 50-110 mm (2.0-4.3 in) <i>Refer to ordering options</i>	APM50-B1N	3.4 kg (7.5 lbs)

INSTALLATION

Please read all installation notes before installing product.



Always attach the antenna using all mounting points.

Do not install antenna with the connectors facing upwards.

EXTERNAL DOCUMENT LINKS

[APM50 Mounting Kit Series Installation Instructions](#)

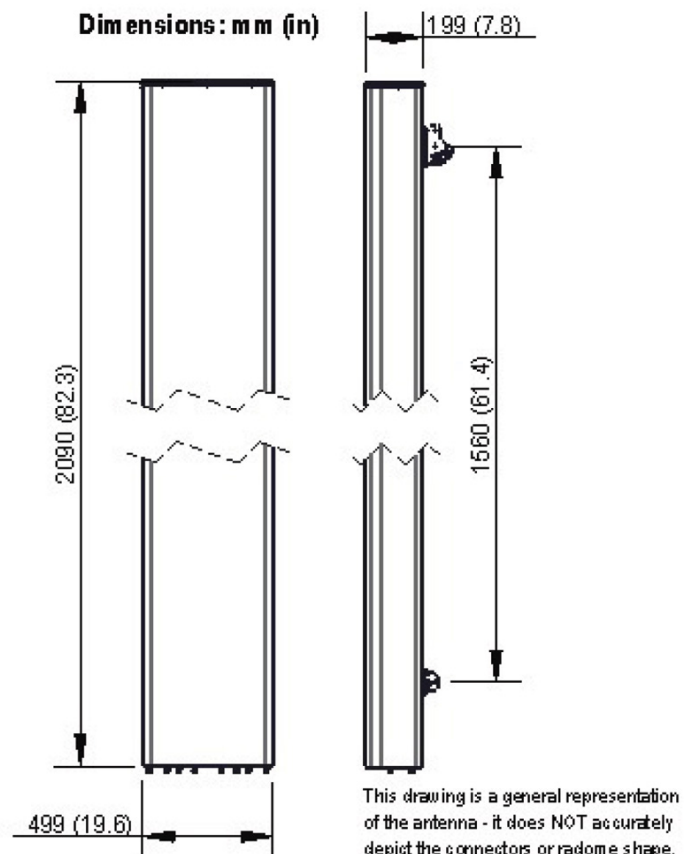

NOTES

Specifications follow BASTA guidelines.

For additional mounting information, please check **External Document Links**.

For Radiating Patterns: [Request pattern files](#)