

APXVBB4L26H2_43-C-I20

APXVBB4L26H2_43-A-I20, APXVBB4L26H2_43-C-I20S, APXVBB4L26H2_43-A-I20S

Features

- 4 ports / 2 cross pol systems in low band (690-960 MHz)
- 8 ports / 4 cross pol systems in high band (1695-2690 MHz)
- Supports 4x4 MIMO in low band and high band
- Integrated and field replaceable SRET
- Dual primary support for antenna sharing
 - Both dynamic and static site sharing modes are offered as default factory settings (see ordering information for more details)
 - Site sharing mapping is reconfigurable remotely
- Optional with Site Sharing feature (Model name suffix -C-I20S, -A-I20S)
- Optional with Direct Pipe No Tilt mounting hardware (Model name suffix -A-I20, -A-I20S)
- Compliant with AISG v2.0 and 3GPP
- Optimized radome for low windload



PRODUCT OVERVIEW	Frequency Range (MHz)	(2x) 690-960		(4x) 1695-2690			
	Array	■ R1	■ R2	■ Y1	■ Y2	■ Y3	■ Y4
	Connector	1-2	3-4	5-6	7-8	9-10	11-12
		12 PORTS					
	Polarization	XPOL					
	Azimuth Beamwidth (avg)	65°			65°		
	Electrical Downtilt	2-12°			2-12°		
Dimensions	2750 x 469 x 205 mm (108.3 x 18.5 x 8.1 in)						

ORDERING OPTIONS Select from the following ordering options

ANTENNA MODEL NUMBER	CONFIGURATION	MOUNTING HARDWARE	MOUNTING PIPE DIAMETER	SHIPPING WEIGHT	MOUNTING HARDWARE WEIGHT
APXVBB4L26H2_43-C-I20	ACU-I20-H12J Internal RET Included	APM50-HS Beam Tilt Kit Included	50-125 mm (2.0-4.9 in)	55.1 kg (121.5 lbs)	9 kg (19.8 lbs)
APXVBB4L26H2_43-A-I20	ACU-I20-H12J Internal RET Included	APM50-HSN Direct Pipe No Tilt Mounting Kit Included	50-125 mm (2.0-4.9 in)	52.1 kg (114.9 lbs)	6 kg (13.2 lbs)
APXVBB4L26H2_43-C-I20S	ACU-X20H Internal RET for Site Sharing Included	APM50-HS Beam Tilt Kit Included	50-125 mm (2.0-4.9 in)	55.2 kg (121.7 lbs)	9 kg (19.8 lbs)
APXVBB4L26H2_43-A-I20S	ACU-X20H Internal RET for Site Sharing Included	APM50-HSN Direct Pipe No Tilt Mounting Kit Included	50-125 mm (2.0-4.9 in)	52.2 kg (115.1 lbs)	6 kg (13.2 lbs)



Quoted performance parameters are provided to offer typical, peak or range values only and may vary as a result of normal testing, manufacturing and operational conditions. Extreme operational conditions and/or stress on structural supports is beyond our control. Such conditions may result in damage to this product. Improvements to products may be made without notice.

APXVBB4L26H2_43-C-I20

APXVBB4L26H2_43-A-I20, APXVBB4L26H2_43-C-I20S, APXVBB4L26H2_43-A-I20S

ELECTRICAL SPECIFICATIONS

■ R1

Frequency Range		MHz	690-960		
		MHz	690-806	790-894	880-960
Polarization		---	±45°		
Gain	Over all Tilts	dBi	16.6 ± 0.3	16.8 ± 0.4	16.8 ± 0.3
	Max Gain	dBi	16.9	17.2	17.1
Azimuth Beamwidth (3 dB)		degrees	66.5° ± 5.5°	63.4° ± 4.9°	64.6° ± 6.2°
Elevation Beamwidth (3 dB)		degrees	8.3° ± 0.5°	7.8° ± 0.4°	7.2° ± 0.4°
Electrical Downtilt		degrees	2-12°		
Impedance		Ohms	50Ω		
VSWR (Return Loss)		---	1.5:1 (-14 dB)		
Passive Intermodulation 3rd Order for 2x20 W Carriers		dBc	-153		
Front-to-Back Ratio, Total Power, ± 30°		dB	19.4	22.3	23.2
First Upper Side Lobe Suppression		dB	16.1	16.8	17.2
Cross Polar Discrimination Over Sector		dB	11.6	9.4	7.6
Cross Polar Discrimination (XPD) at Mechanical Boresight (0°)		dB	26.9	28.3	27.6
Maximum Effective Power Per Port		Watts	250 W		
Cross Polar Isolation		dB	26		
Interband Isolation		dB	26		

Specifications follow BASTA guidelines.

ELECTRICAL SPECIFICATIONS

■ R2

Frequency Range		MHz	690-960		
		MHz	690-806	790-894	880-960
Polarization		---	±45°		
Gain	Over all Tilts	dBi	16.4 ± 0.3	16.7 ± 0.4	16.7 ± 0.4
	Max Gain	dBi	16.7	17.1	17.1
Azimuth Beamwidth (3 dB)		degrees	65.1° ± 5.4°	61.9° ± 4°	63.3° ± 5.5°
Elevation Beamwidth (3 dB)		degrees	8.3° ± 0.4°	7.7° ± 0.4°	7.2° ± 0.4°
Electrical Downtilt		degrees	2-12°		
Impedance		Ohms	50Ω		
VSWR (Return Loss)		---	1.5:1 (-14 dB)		
Passive Intermodulation 3rd Order for 2x20 W Carriers		dBc	-153		
Front-to-Back Ratio, Total Power, ± 30°		dB	19.7	22.6	23
First Upper Side Lobe Suppression		dB	15.8	17.3	15.7
Cross Polar Discrimination Over Sector		dB	10.9	9.1	7.7
Cross Polar Discrimination (XPD) at Mechanical Boresight (0°)		dB	25.5	31.1	26.1
Maximum Effective Power Per Port		Watts	250 W		
Cross Polar Isolation		dB	26		
Interband Isolation		dB	26		

Specifications follow BASTA guidelines.

Quoted performance parameters are provided to offer typical, peak or range values only and may vary as a result of normal testing, manufacturing and operational conditions. Extreme operational conditions and/or stress on structural supports is beyond our control. Such conditions may result in damage to this product. Improvements to products may be made without notice.

65°

2750 mm

INTEGRATED RET

SITE SHARING OPTIONAL

APXVBB4L26H2_43-C-I20

APXVBB4L26H2_43-A-I20, APXVBB4L26H2_43-C-I20S, APXVBB4L26H2_43-A-I20S

ELECTRICAL SPECIFICATIONS

■ Y1

Frequency Range		MHz	1695-2690				
		MHz	1695-1880	1850-1990	1920-2170	2300-2400	2490-2690
Polarization		---	±45°				
Gain	Over all Tilts	dBi	16.5 ± 0.8	17.3 ± 0.4	17.5 ± 0.6	17.4 ± 0.5	17.2 ± 0.6
	Max Gain	dBi	17.3	17.7	18.1	17.9	17.8
Azimuth Beamwidth (3 dB)		degrees	67.8° ± 6.7°	61.9° ± 5.6°	60.6° ± 6.3°	56.7° ± 5.2°	55.4° ± 6.8°
Elevation Beamwidth (3 dB)		degrees	6.7° ± 0.6°	6.2° ± 0.2°	5.9° ± 0.5°	5.3° ± 0.3°	4.8° ± 0.2°
Electrical Downtilt		degrees	2-12°				
Impedance		Ohms	50Ω				
VSWR (Return Loss)		---	1.5:1 (-14 dB)				
Passive Intermodulation 3rd Order for 2x20 W Carriers		dBc	-153				
Front-to-Back Ratio, Total Power, ± 30°		dB	21.9	22.3	22.4	23.7	23.6
First Upper Side Lobe Suppression		dB	16.1	15.5	15.4	17.3	17.1
Cross Polar Discrimination Over Sector		dB	7.5	3.9	3.5	0.6	0.4
Cross Polar Discrimination (XPD) at Mechanical Boresight (0°)		dB	15.3	16.1	16.4	15.7	19.6
Maximum Effective Power Per Port		Watts	200 W				
Cross Polar Isolation		dB	26				
Interband Isolation		dB	28				

Specifications follow BASTA guidelines.

ELECTRICAL SPECIFICATIONS

■ Y2

Frequency Range		MHz	1695-2690				
		MHz	1695-1880	1850-1990	1920-2170	2300-2400	2490-2690
Polarization		---	±45°				
Gain	Over all Tilts	dBi	16.5 ± 0.7	17.1 ± 0.4	17.4 ± 0.6	16.9 ± 0.4	16.9 ± 0.5
	Max Gain	dBi	17.2	17.5	18.0	17.3	17.4
Azimuth Beamwidth (3 dB)		degrees	69.7° ± 4.1°	63.8° ± 5.6°	60.8° ± 4.4°	57.9° ± 4.2°	58.8° ± 4.5°
Elevation Beamwidth (3 dB)		degrees	6.5° ± 0.4°	6.1° ± 0.3°	5.7° ± 0.5°	5.2° ± 0.3°	4.8° ± 0.3°
Electrical Downtilt		degrees	2-12°				
Impedance		Ohms	50Ω				
VSWR (Return Loss)		---	1.5:1 (-14 dB)				
Passive Intermodulation 3rd Order for 2x20 W Carriers		dBc	-153				
Front-to-Back Ratio, Total Power, ± 30°		dB	27.6	24.9	26.3	26.3	26.4
First Upper Side Lobe Suppression		dB	15.9	16.2	15	17.5	17.7
Cross Polar Discrimination Over Sector		dB	6.2	8.3	3.8	2.5	0.7
Cross Polar Discrimination (XPD) at Mechanical Boresight (0°)		dB	17.5	22.8	22.5	17.2	19.3
Maximum Effective Power Per Port		Watts	200 W				
Cross Polar Isolation		dB	26				
Interband Isolation		dB	28				

Specifications follow BASTA guidelines.

Quoted performance parameters are provided to offer typical, peak or range values only and may vary as a result of normal testing, manufacturing and operational conditions. Extreme operational conditions and/or stress on structural supports is beyond our control. Such conditions may result in damage to this product. Improvements to products may be made without notice.

65°

2750 mm

INTEGRATED RET

SITE SHARING OPTIONAL

APXVBB4L26H2_43-C-I20

APXVBB4L26H2_43-A-I20, APXVBB4L26H2_43-C-I20S, APXVBB4L26H2_43-A-I20S

ELECTRICAL SPECIFICATIONS

■ Y3

Frequency Range		MHz	1695-2690				
		MHz	1695-1880	1850-1990	1920-2170	2300-2400	2490-2690
Polarization		---	±45°				
Gain	Over all Tilts	dBi	16.6 ± 0.8	17.2 ± 0.4	17.4 ± 0.6	17.4 ± 0.6	17.3 ± 0.6
	Max Gain	dBi	17.4	17.6	18.0	18.0	17.9
Azimuth Beamwidth (3 dB)		degrees	67.3° ± 5.4°	64.9° ± 4.7°	62.4° ± 7.1°	55.8° ± 4.5°	55° ± 6.6°
Elevation Beamwidth (3 dB)		degrees	6.7° ± 0.5°	6.2° ± 0.3°	5.8° ± 0.5°	5.3° ± 0.4°	4.8° ± 0.2°
Electrical Downtilt		degrees	2-12°				
Impedance		Ohms	50Ω				
VSWR (Return Loss)		---	1.5:1 (-14 dB)				
Passive Intermodulation 3rd Order for 2x20 W Carriers		dBc	-153				
Front-to-Back Ratio, Total Power, ± 30°		dB	23.4	23.6	24	25	24
First Upper Side Lobe Suppression		dB	16.6	14.5	14.3	17.1	16.8
Cross Polar Discrimination Over Sector		dB	5.9	5.7	4.3	2.2	0.6
Cross Polar Discrimination (XPD) at Mechanical Boresight (0°)		dB	17.2	19	18.1	17.8	20.5
Maximum Effective Power Per Port		Watts	200 W				
Cross Polar Isolation		dB	26				
Interband Isolation		dB	28				

Specifications follow BASTA guidelines.

ELECTRICAL SPECIFICATIONS

■ Y4

Frequency Range		MHz	1695-2690				
		MHz	1695-1880	1850-1990	1920-2170	2300-2400	2490-2690
Polarization		---	±45°				
Gain	Over all Tilts	dBi	16.5 ± 0.6	17.1 ± 0.4	17.4 ± 0.6	16.8 ± 0.4	16.8 ± 0.5
	Max Gain	dBi	17.1	17.5	18.0	17.2	17.3
Azimuth Beamwidth (3 dB)		degrees	69.3° ± 4.4°	63.5° ± 5.9°	60.5° ± 4°	58° ± 4.6°	57.9° ± 4.8°
Elevation Beamwidth (3 dB)		degrees	6.6° ± 0.4°	6.1° ± 0.3°	5.7° ± 0.5°	5.2° ± 0.3°	4.9° ± 0.3°
Electrical Downtilt		degrees	2-12°				
Impedance		Ohms	50Ω				
VSWR (Return Loss)		---	1.5:1 (-14 dB)				
Passive Intermodulation 3rd Order for 2x20 W Carriers		dBc	-153				
Front-to-Back Ratio, Total Power, ± 30°		dB	25.8	25.1	25.1	25.7	26.2
First Upper Side Lobe Suppression		dB	16.5	17.3	16.4	15.3	15.8
Cross Polar Discrimination Over Sector		dB	6.2	8.6	3.6	2.5	0.5
Cross Polar Discrimination (XPD) at Mechanical Boresight (0°)		dB	17.7	22.1	22.1	19.5	19.8
Maximum Effective Power Per Port		Watts	200 W				
Cross Polar Isolation		dB	26				
Interband Isolation		dB	28				

Specifications follow BASTA guidelines.

Quoted performance parameters are provided to offer typical, peak or range values only and may vary as a result of normal testing, manufacturing and operational conditions. Extreme operational conditions and/or stress on structural supports is beyond our control. Such conditions may result in damage to this product. Improvements to products may be made without notice.

APXVBB4L26H2_43-C-I20

APXVBB4L26H2_43-A-I20, APXVBB4L26H2_43-C-I20S, APXVBB4L26H2_43-A-I20S

BOTTOM VIEW - LABELING



ARRAY LAYOUT

ARRAY	FREQUENCY	CONNECTOR	CONNECTOR TYPE	RET	AISG RET UID
■ R1	690-960 MHz	1-2	(2x) 4.3-10 Female	R1	RFxxxxxxxxxx-R1
■ R2	690-960 MHz	3-4	(2x) 4.3-10 Female	R2	RFxxxxxxxxxx-R2
■ Y1	1695-2690 MHz	5-6	(2x) 4.3-10 Female	Y1	RFxxxxxxxxxx-Y1
■ Y2	1695-2690 MHz	7-8	(2x) 4.3-10 Female	Y2	RFxxxxxxxxxx-Y2
■ Y3	1695-2690 MHz	9-10	(2x) 4.3-10 Female	Y3	RFxxxxxxxxxx-Y3
■ Y4	1695-2690 MHz	11-12	(2x) 4.3-10 Female	Y4	RFxxxxxxxxxx-Y4

NOTE: RET motors will tilt one at a time, not simultaneously

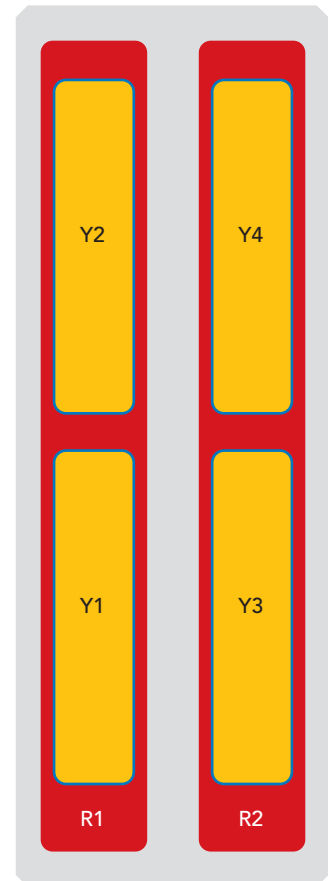

The illustration is not shown to scale.

Quoted performance parameters are provided to offer typical, peak or range values only and may vary as a result of normal testing, manufacturing and operational conditions. Extreme operational conditions and/or stress on structural supports is beyond our control. Such conditions may result in damage to this product. Improvements to products may be made without notice.

65°

2750 mm

INTEGRATED RET

SITE SHARING OPTIONAL

APXVBB4L26H2_43-C-I20

APXVBB4L26H2_43-A-I20, APXVBB4L26H2_43-C-I20S, APXVBB4L26H2_43-A-I20S

MECHANICAL SPECIFICATIONS

Length	mm (in)	2750 (108.3)
Width	mm (in)	469 (18.5)
Depth	mm (in)	205 (8.1)
Net Weight - Antenna Only	kg (lbs)	39 (86)
Wind Load Rated at 150 km/h (93 mph)	Frontal, Resultant	N (lbf) 763 (172)
	Side, Resultant	N (lbf) 792 (178)
	Rear, Resultant	N (lbf) 795 (179)
	Maximum, Resultant	N (lbf) 1269 (285)
	Maximum, Drag Force	N (lbf) 1009 (227)
Survival Wind Speed	km/h (mph)	200 (124)
Connector Type	--	(12x) 4.3-10 Female, (2x) AISG Connectors (1 Male, 1 Female) at Bottom Site Sharing: (4x) AISG Connectors (2 Male, 2 Female) at Bottom
Radome Color	---	Light Grey RAL7035
Radome Material	---	Fiberglass
Lightning Protection	---	Direct Ground
Shipping	Packing Size (Length x Width x Depth)	mm (in) 2930 x 544 x 330 (115.4 x 21.4 x 13)

ENVIRONMENTAL SPECIFICATIONS

Environmental Standard	---	ETS 300 019
Operating Temperature	degrees	-40° to +60° C (-40° to +140° F)
Product Environmental Compliance	---	Product is RoHS Compliant

Quoted performance parameters are provided to offer typical, peak or range values only and may vary as a result of normal testing, manufacturing and operational conditions. Extreme operational conditions and/or stress on structural supports is beyond our control. Such conditions may result in damage to this product. Improvements to products may be made without notice.

APXVBB4L26H2_43-C-I20

APXVBB4L26H2_43-A-I20, APXVBB4L26H2_43-C-I20S, APXVBB4L26H2_43-A-I20S

ACCESSORIES

Accessories may be ordered separately unless otherwise indicated.

ITEM	MODEL NUMBER	WEIGHT
Beam Tilt Mounting Bracket Kit for Pole Diameter 50-125 mm (2.0-4.9 in) <i>Refer to ordering options</i>	APM50-HS	9 kg (19.8 lbs)
Direct Pipe No Tilt Bracket Kit for Pole Diameter 50-125 mm (2.0-4.9 in) <i>Refer to ordering options</i>	APM50-HSN	6 kg (13.2 lbs)

INSTALLATION

Please read all installation notes before installing product.



Always attach the antenna using all mounting points.

Do not install antenna with the connectors facing upwards.

EXTERNAL DOCUMENT LINKS

[APM50 Mounting Kit Series Installation Instructions](#)

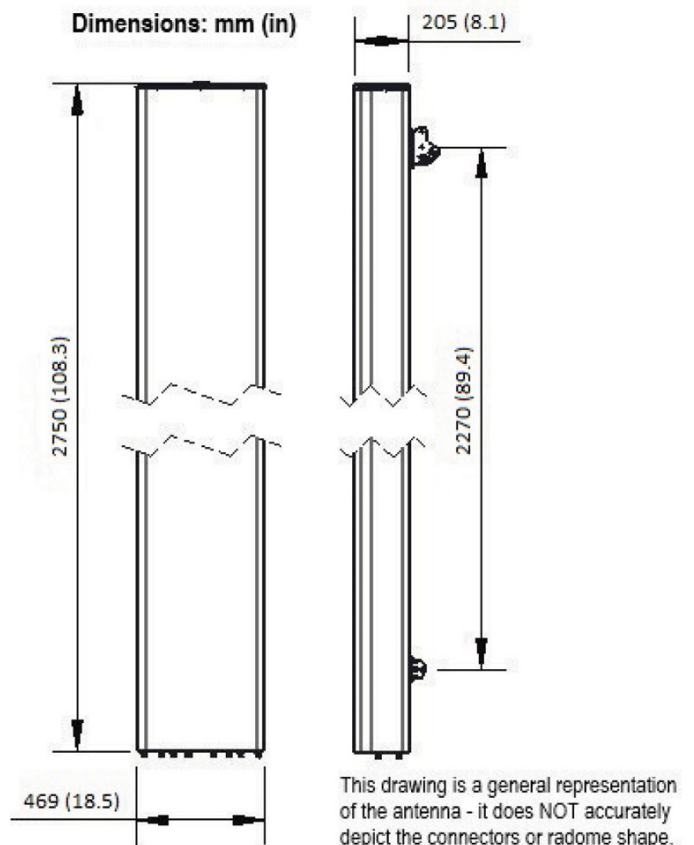

NOTES

Specifications follow BASTA guidelines.

For additional mounting information, please check **External Document Links**.

For Radiating Patterns: [Request pattern files](#)