

Amphenol Antenna Solutions



**APM50-W3 MOUNTING KIT
INSTALLATION INSTRUCTIONS**

REV. 4.0 | 2024.05

Mounting Instructions for APM50-W3 Kit

SUMMARY

Applications.....	3
Mechanical Specifications	3
Features	3
Assembly and Installation	3
Installation and Tilt Adjustment Steps	5
Maintenance	5

Mounting Instructions for APM50-W3 Kit

APPLICATIONS

The APM50 kits are mounting hardware options to be used for Base Station antennas.

MECHANICAL SPECIFICATIONS

- Weight of Kit (kg): 4.3
- Mounting kit material: Q235 Galvanized Steel
- Packaging material: EPS
- Dynamometric Tools Required: Wrench and Spanner

FEATURES

- The upper and lower brackets enable to adjust the mechanical tilt.
- All kits fully upgradable
- Pipe diameter: 50-115mm
- The adjustable tilt range depends on the different antenna models



ASSEMBLY AND INSTALLATION

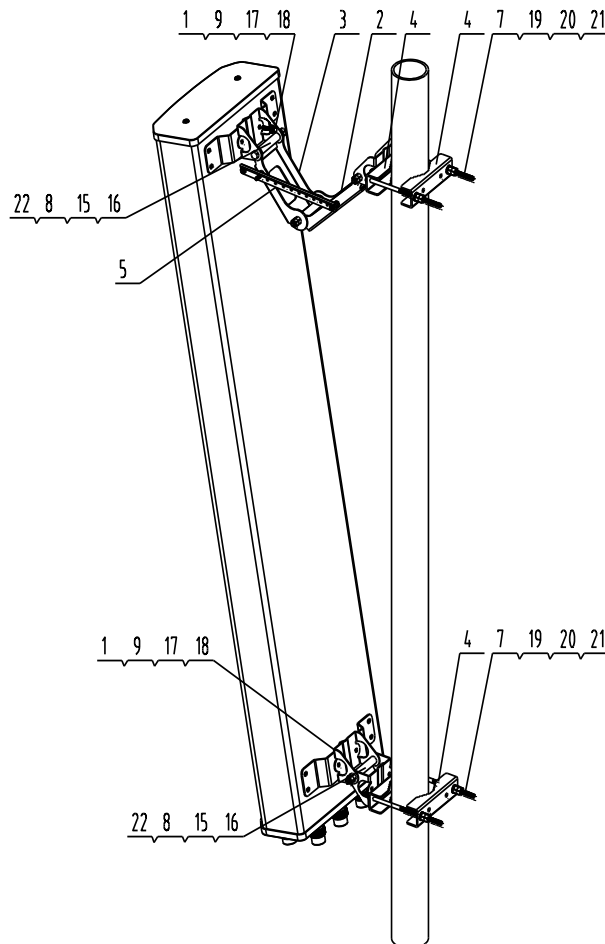

Mounting Instructions for APM50-W3 Kit

Number	Names	Quantity
1	Bracket	4
2	Antenna Pivot Arm 1	1
3	Antenna Pivot Arm 2	1
4	Mount Clamp	4
5	Calibration Tablets	1
6	M8*20 Bolt	8
7	M12*180 Bolt	4
8	M10*110 Bolt	4
9	M6*30 Bolt	2
10	M6 Hex Nut	6
11	M10 Hex Nut	4
12	Ø10 Spring Washer	4
13	Ø10 Flat Washer	4
14	M8 Hex Nut	8
15	Ø8 Flat Washer	8
16	Ø8 Spring Washer	8
17	Ø6 Flat Washer	2
18	Ø6 Spring Washer	2
19	M12 Hex Nut	8
20	Ø12 Spring Washer	4
21	Ø12 Flat Washer	4
22	Aluminum Tube Ø16*75.5	4

Mounting Instructions for APM50-W3 Kit

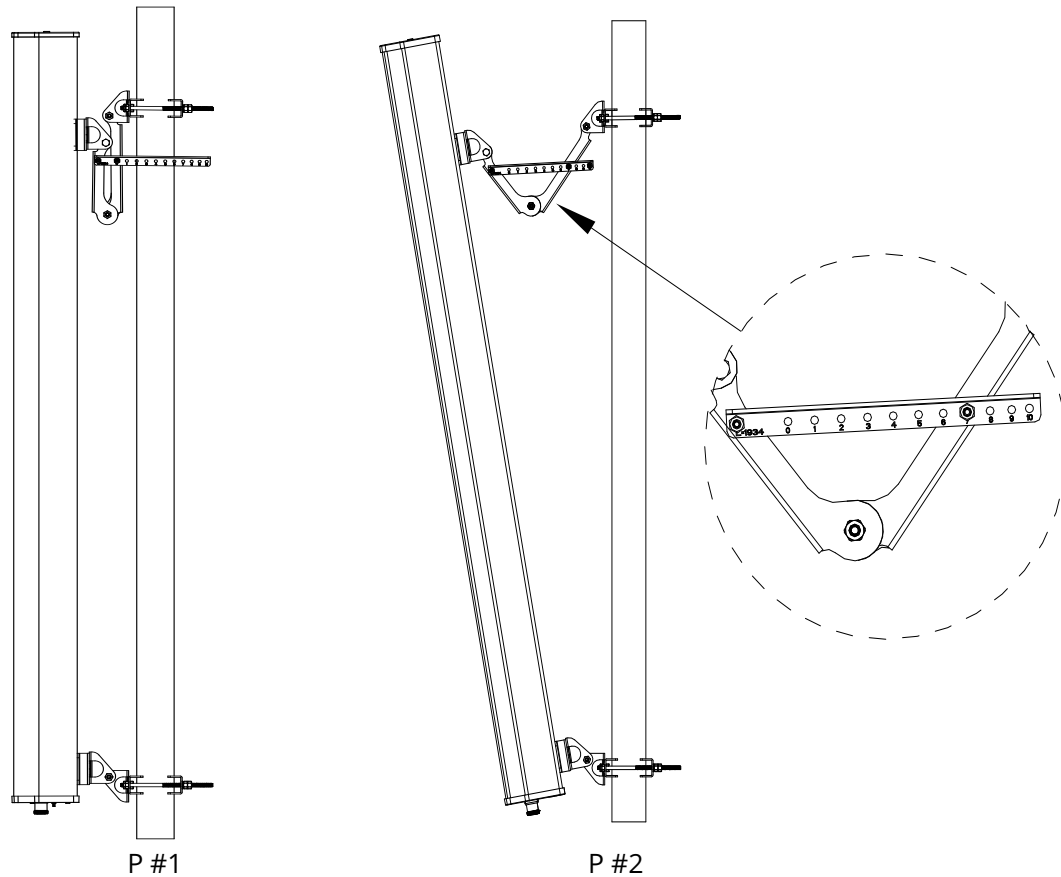

Installation and Tilt Adjustment Steps

1. To fix the antenna on the pole, refer to P #1.
2. To adjust the mechanical tilt as requirements, refer to P #2.
3. To tighten all the fasteners (see below).

TIGHTENING NUT HEX TORQUE VALUES

Diameter	Torque	Wrench Type
M6	10 Nm	10mm
M8	20 Nm	13mm
M10	35 Nm	17mm
M12	60 Nm	19mm

TIGHTENING CONNECTOR TORQUE VALUES

Connector Type	Torque
7-16 DIN	25 Nm

MAINTENANCE

Under normal conditions, no maintenance is necessary. However, the antenna should be visually inspected at regular intervals for damage (e.g. due to lightning strikes, and falling ice). Periodic checks should be performed to verify correct torque and bracket clearance settings. Accessories provided exclusively by RFS.

Mounting Instructions for APM50-W3 Kit

NAR

Conover & Meriden
+1 (779) 970-1605
Technical Support
support@amphenol-antennas.com

APAC

Shanghai
+86 (21) 3773 8888
Technical Support
apac.bsa.support@amphenol-antennas.com

EMEA & LATAM

Amboise & Lannion
Technical Support
techsupport@amphenol-antennas.com