

Amphenol Antenna Solutions



**APM50-B3 MOUNTING KIT
INSTALLATION INSTRUCTIONS**

REV. 4.0 | 2024.05

Mounting Instructions for APM50-B3 Kit

SUMMARY

1. Applications.....	3
2. Mechanical Specifications	3
3. Assembly and Installation	3
Installation Preparation.....	3
Installation Tools	3
Installation Instructions.....	4
4. Antenna Mechanical Downtilt Range.....	5
5. Material list.....	6

Mounting Instructions for APM50-B3 Kit

1. APPLICATIONS

The APM50 kits are mounting hardware options to be used for Base Station antennas.

2. MECHANICAL SPECIFICATIONS

- Pole Diameter: 60-110 mm
- Weight: 2.7 kg

3. ASSEMBLY AND INSTALLATION

Installation Preparation

1. Check each package against packing list.
2. Observe safe working at heights.
3. Ensure lightning protection is applied.
4. Annual maintenance is recommended to antenna system.

Installation Tools

TIGHTENING NUT TORQUE VALUES

Nut	Wrench	Torque
M6	10(11)mm	7-10Nm
M8	13(14)mm	18-22Nm
M10	16(17)mm	32-40Nm

TIGHTENING CONNECTOR TORQUE VALUES

Connector	Wrench
4.3-10	5-8Nm
7-16	18-22Nm

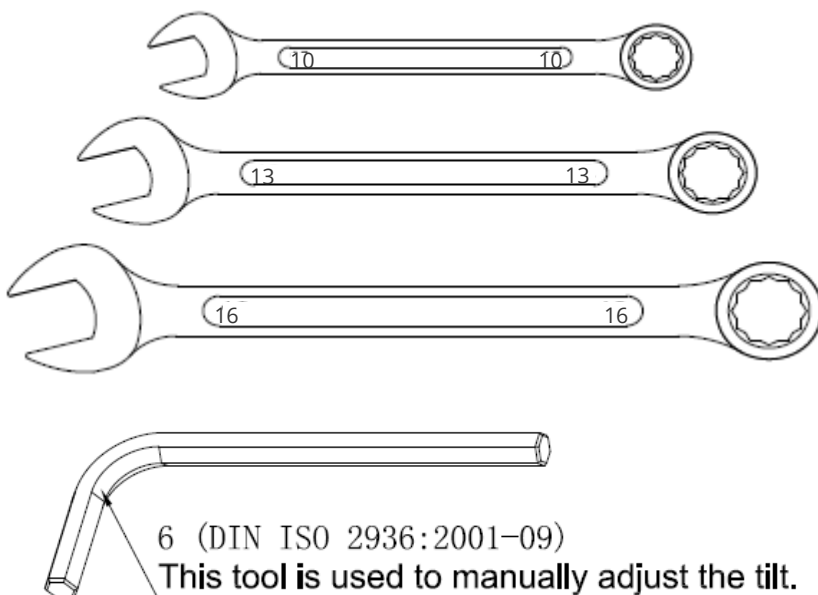

Mounting Instructions for APM50-B3 Kit

Installation Instructions

Step 1

Pre-assemble the top and bottom mounting brackets. Tighten the U Clamp with M6 bolts (torque 8Nm).

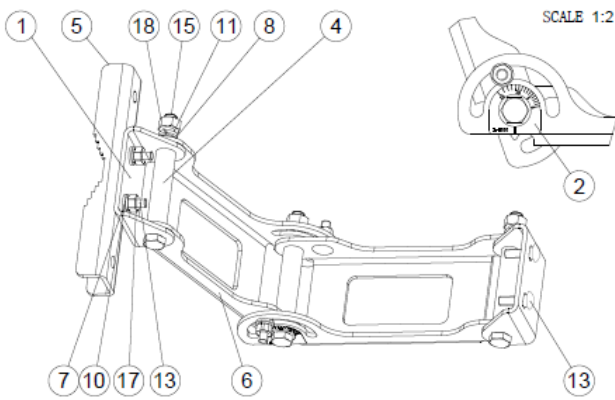

Top Mounting Bracket

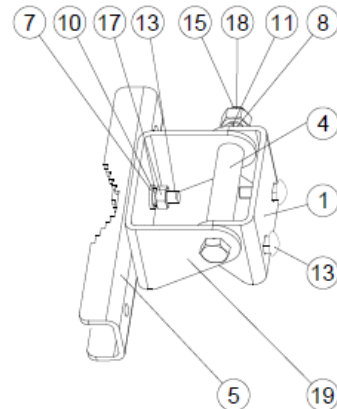

Bottom Mounting Bracket

Step 2

Assemble mounting brackets to the antenna with four M6 bolts (torque 8Nm).

Step 3

1. Adjust tilt to 0° and tighten nut A;
2. Fasten antenna to pole vertically with M10x150 bolts (torque 32Nm).

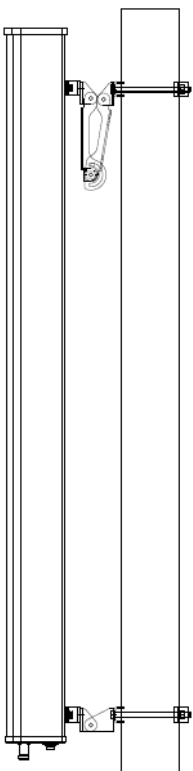

Step 2

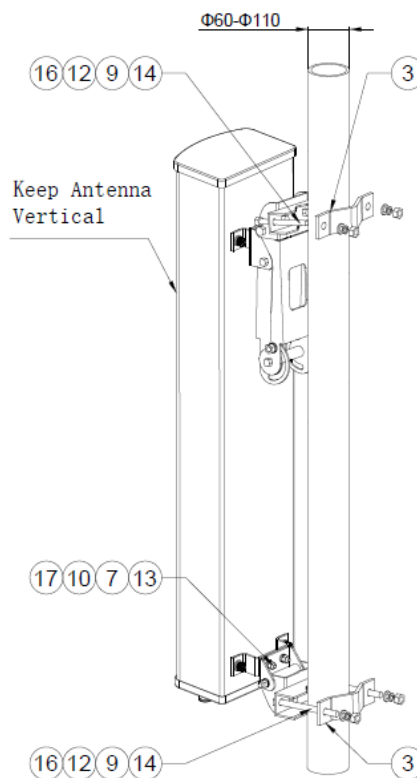

Step 3

Mounting Instructions for APM50-B3 Kit

Step 4

Loose nut 18 and adjust downtilt mounting bracket to achieve required downtilt angle.

Step 5

Tighten nut 18 to fix antenna downtilt angle.

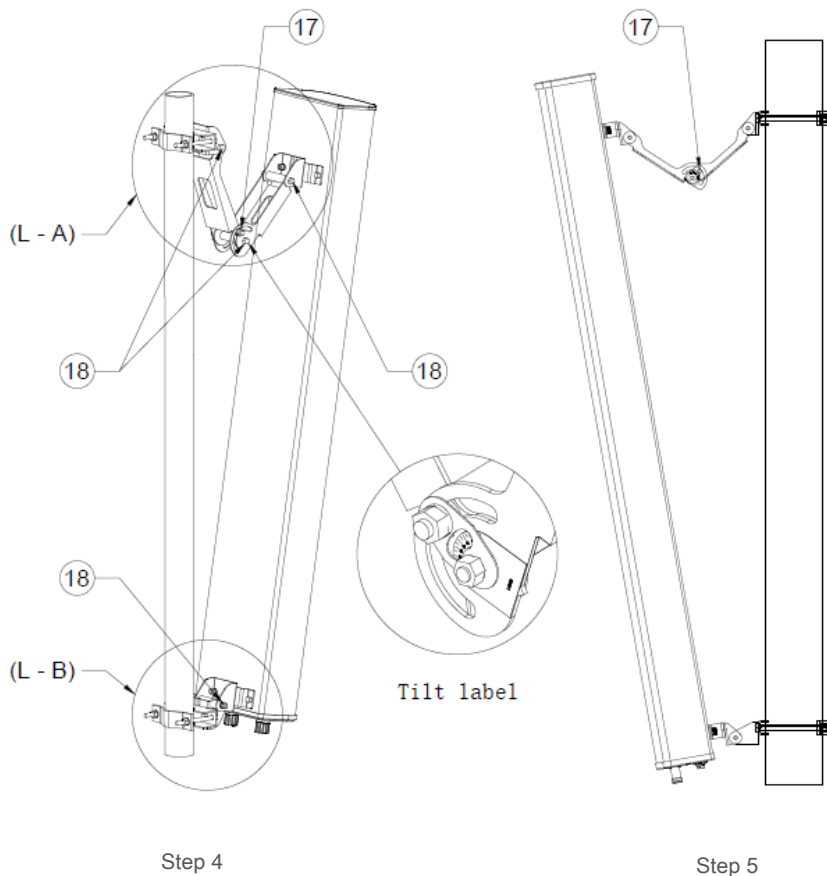

4. ANTENNA MECHANICAL DOWNTILT RANGE

Antenna Length (mm)	Mechanical Downtilt Range (°)
1000	0-15
680	0-16
545	0-20
500	0-25

Mounting Instructions for APM50-B3 Kit

5. MATERIAL LIST

ITEM#	DESCRIPTION	QTY L-A	QTY L-B
1	U Bracket 1	2	1
2	Tilt Label	2	0
3	U Clamp	1	1
4	Aluminum Tube	3	1
5	U Clamp	1	1
6	Bracket	2	0
7	Plain Washer (M6)	6	4
8	Plain Washer (M8)	3	1
9	Plain Washer (M10)	2	2
10	Spring Washer (M6)	6	4
11	Spring Washer (M8)	3	1
12	Spring Washer (M10)	2	2
13	Square Neck Bolt (M6x20)	6	4
14	Hex Bolt (M10x150)	2	2
15	Hex Bolt (M8x90)	3	1
16	Nut (M10)	2	2
17	Nut (M6)	6	4
18	Nut (M8)	3	1
19	U Bracket 2	0	1

Mounting Instructions for APM50-B3 Kit

NAR

Conover & Meriden
+1 (779) 970-1605
Technical Support
support@amphenol-antennas.com

APAC

Shanghai
+86 (21) 3773 8888
Technical Support
apac.bsa.support@amphenol-antennas.com

EMEA & LATAM

Amboise & Lannion
Technical Support
techsupport@amphenol-antennas.com