



ANTENNA LINE DEVICE CONTROL (ALDC) SOFTWARE

User Guide v2.0



Contents

1. Introduction	2
Product Functions	2
SmartTilt Technology	3
2. ALDC Software Installation Setup	4
Setup Preparation	4
Downloading ALDC Software	5
Extracting ALDC Software	7
Installing ALDC Software	7
3. Launching the ALDC System Software	9
4. System Configuration	10
System Settings	10
Changing System Settings	10
Adapter Settings	11
Changing Adapter Settings	11
Changing Adapter Settings, cont.	12
5. Using the ALDC System Software	13
Device Scan	13
Add a Device	16
Refresh	17
Tool Bar Commands	17
RET Detail Settings	20
Uploading a New Configuration File to a RET	21
Changing the Frequency Band	22
Set Tilt	23
Get Tilt	23
Calibration	24
Download Software—RET and TMA	25
TMA Detail Settings	26
Antenna Installation Data (See “Antenna Installation Data”)	26
Antenna Model Data (See “Antenna Model Data”)	26
TMA Model Data	27
Set Mode	27
Get Mode	28
Set Gain	28
Get Gain	28
Site Report	29
Antenna Model Management	30
Add a Vendor	31
AISG Vendor Codes:	32
Delete a Vendor	33
Add an Antenna Model	33
Delete an Antenna Model	33
Appendix A: Changing AISG Communications Mode	34
Switching Between Communication Modes	34
Appendix B: Remote Azimuth Steering (RAS)	35
Overview	35
RAS Device Setup	36
The Antenna Azimuth Setting	37

1. Introduction

The Antenna Line Device Control (ALDC) system is a portable primary controller used for configuration and control of AISG v1.1 and/or AISG v2.0 devices at a cell site. The system consists of a Portable Control Unit (PCU), data cables, a 24v power supply and ALDC software, which is installed on a user's laptop computer. This system is an upgrade to Amphenol Antenna Solutions' previous PCU-2 system that was only able to control AISG v1.1 devices.

Hardware	Software	Serial Interface	AISG Version
PCU-2 (previous version)	ALDC v1.x	RS232 serial port	AISG v1.1 (only)
PCU-4	ALDC v2.x	USB 1.1 or 2.0	AISG v1.1 or v2.0

Product Functions

The major functions provided in the ALDC system include:

Antenna Remote Electrical Tilt/Remote Azimuth Steering Adjustment

- Antenna electrical tilt setting
- Antenna azimuth steering setting
- Antenna self-test and reset
- Antenna installation data maintenance
- Antenna model management
- Software Download

AISG TMA Adjustment

- TMA gain setting
- TMA mode setting
- TMA self-test and reset
- TMA installation data maintenance
- Software Download

Device Calibration

Device Configuration

SmartTilt Technology

The system uses local or remote commands to adjust equipment for the desired antenna performance.

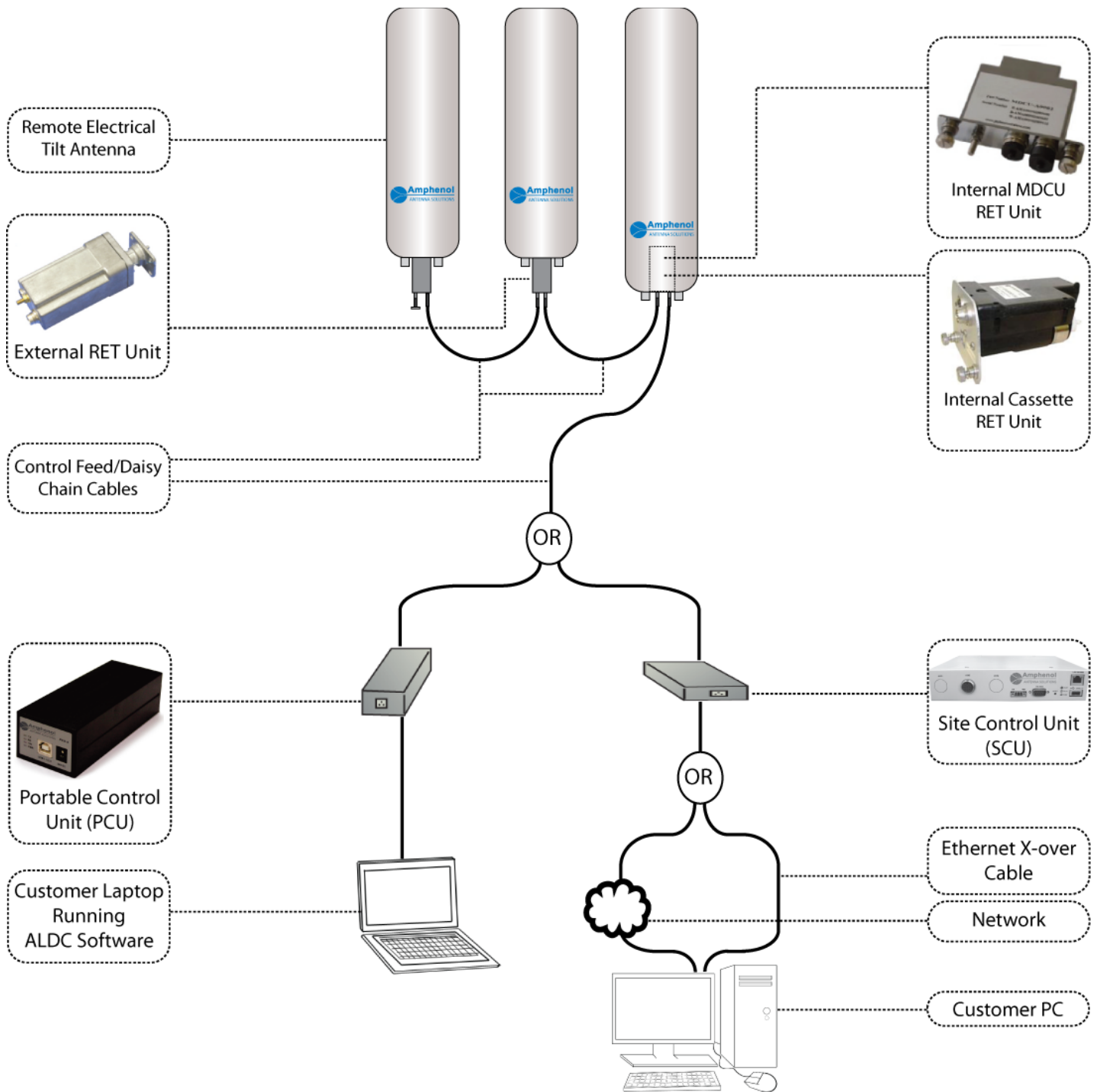

2. ALDC Software Installation Setup

Setting up the ADLC software involves three steps: downloading, extracting, and then installing.

Setup Preparation

Make sure prior to setup that the ADLC system you received includes the following:

- Portable Control Unit (PCU-4)
- USB Data Cable
- AISG Control Cable
- 24V Power Supply
- ALDC software v2.0 for Microsoft Windows. The best way to obtain the latest software is to download it from the Amphenol Antennas Web site.

NOTE Before installing RET antennas, Amphenol Antenna Solutions strongly suggests connecting each actuator to the controller (PCU-4, Node B, or other antenna vendor controller) and testing the connection on the ground. Doing so will ensure that each antenna is in working order *prior* to climbing the tower, which might prevent reascending the tower.

IMPORTANT!

The PCU-4 USB Cable **MUST** be disconnected from the computer's USB port during the software installation process. If the USB cable is connected to the computer, the USB-RS485 drivers will **NOT** load properly and programming the RET will not be possible.



Downloading ALDC Software

Downloading ALDC Software from CD

Not all users have the CD; if you are missing the CD skip this section. Instead refer to “Downloading ALDC Software from the Internet (Windows XP)” or “Downloading ALDC Software from the Internet (Windows 7)”, determining which operating system you are using.

1. Insert the ALDC software CD in the computer and double-click on the ALDC Setup icon. Your Web browser displays the ALDC Setup home screen.

Click on the [Installation] button.

2. Click the [Run] button to start the download. Click [Run] to confirm the download when the security warning dialog is displayed.

3. Click the [Run] button to verify the download publisher.

4. The ALDC v2.0d Setup window is displayed. Make sure that the checkboxes for “Install USB Driver” and “Install Antenna Line Device Control v2.0d” are checked and then click the [Next] button.

5. Make sure “ALDC v2.0d” is highlighted in blue and then click [Next] button to begin downloading the file.

6. Select the installation folder and then click the [Install] button.

7. The screen displays the download progress window. **DO NOT** click the [Close] button on this window because that will stop the program download.

When the download is complete the message window displays “Completed” above the blue bar line. Click the [Yes] button to restart your computer and finish the installation.

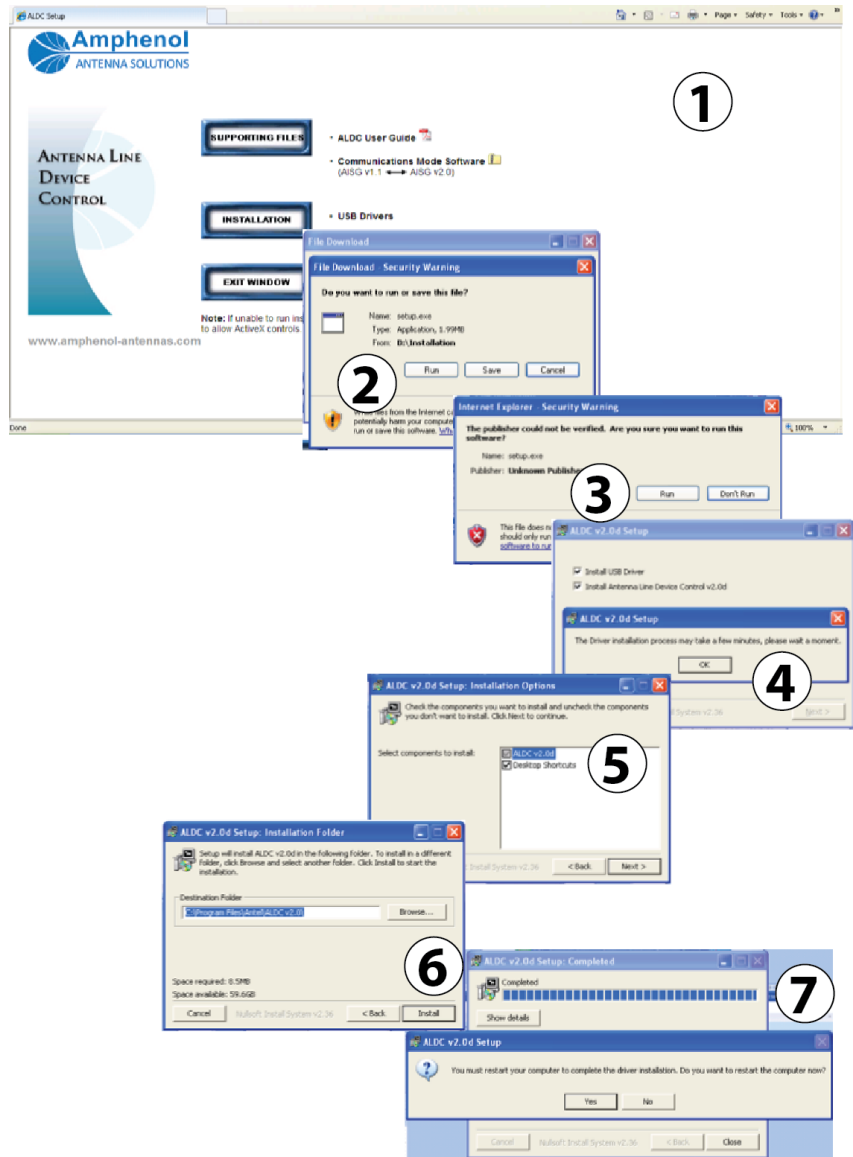

Downloading ALDC Software from the Internet

1. On the control computer, open a Web browser (Internet Explorer recommended) and go to the Amphenol Antenna Web site (<http://www.amphenol-antennas.com>). The Web browser screen displays the Amphenol Antennas home page.
2. Select **Products**→**RET Control Systems**→**RET System Software Downloads** from the Products pull-down selection list. The Web browser opens the RET System Software Downloads page.
3. The RET System Software Downloads page displays links to software files that can be downloaded. Click on the link **SmartTilt Antenna Line Device Control (ALDC) Software for PCU-KIT-4-xx**.
4. This opens a file download prompt. Click the **Save** button.

NOTE Windows 7 (4a) and Windows XP (4b) download prompts are slightly different in appearance.

5. Select your PC desktop as the target download location. The screen will display the download status, and when completed the file **ALDCv2-0d-.zip** is on your computer.
6. When the download is complete, click on the **Open** button.



Extracting ALDC Software

1. Click on the file **Amphenol Antenna Solutions ALDC 2.0 for PCU-4.zip**. The screen displays the Extraction Wizard tool. Click the [Next] button to extract the files.
2. Click the [Finish] button. All of the files you need to install the ALDC software have been extracted into the target directory on your PC.
3. The target directory displays the folder **Antenna Line Device Control Software (ALDC) v2.0 for PCU-4**.

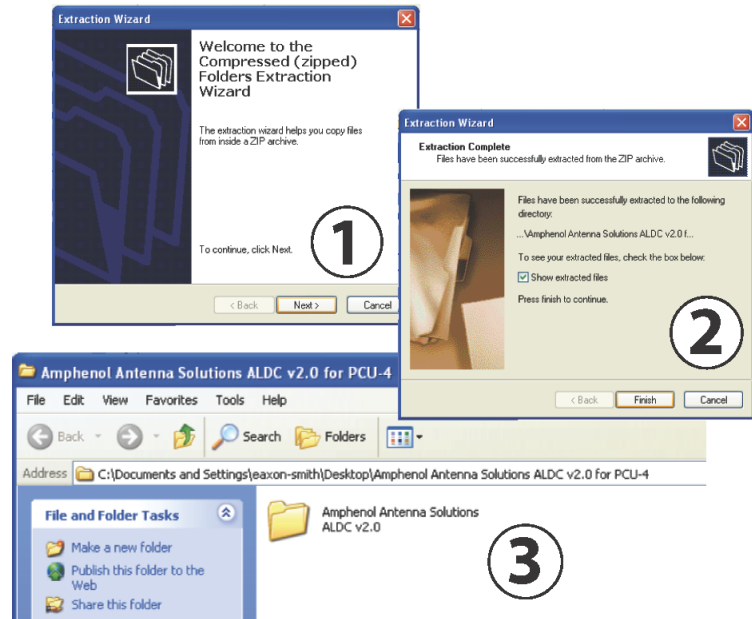

Installing ALDC Software

Installing ALDC Software (Windows XP)

1. Double-click on the folder **Antenna Line Device Control Software (ALDC) v2.0 for PCU-4**. The folder contains an autorun utility and the **Installation** folder.
2. Double-click the **Installation** folder to open it, then double-click on the **Setup** icon to start the **ALDC v2.0 Setup** tool.
3. Leave both installation options checked, and click the [Next] button. When the installation is complete your PC desktop displays the software icons, and it alerts you that the USB driver has been installed.

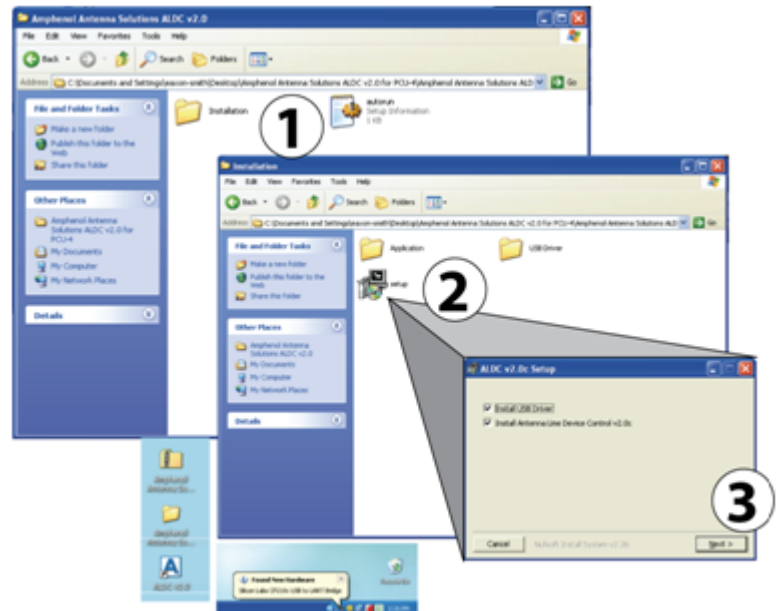

Installing ALDC Software (Windows 7)

1. Double-click on the folder **Antenna Line Device Control Software (ALDC) v2.0 for PCU-4**. The folder contains an autorun utility and the **Installation** folder.
2. Double-click the **Installation** folder to open it, and then double-click on the **Setup** icon to start the **ALDC v2.0 Setup** tool. A confirmation window will appear. Click [Run], which will cause a new window to appear.
3. Leave both installation options checked and click the **Next** button. **DO NOT** click the [Close] button on this window while the installation is in progress, because that will interrupt the installation. When the installation is complete your PC desktop displays the software icons and alerts you that the USB driver has been installed.
4. **Now**, plug the USB connector from the PCU-4 into one of your computers USB ports. If your speaker(s) are enabled, you should hear an audible tone after the PCU-4 connects.
5. Click on the **ALDC** icon on the desktop to start the application. The screen displays the ALDC home screen.
6. Check the **Port: COM** number at the bottom of the home screen. Any number other than zero (0) means the USB cable is connected and detected by the system.

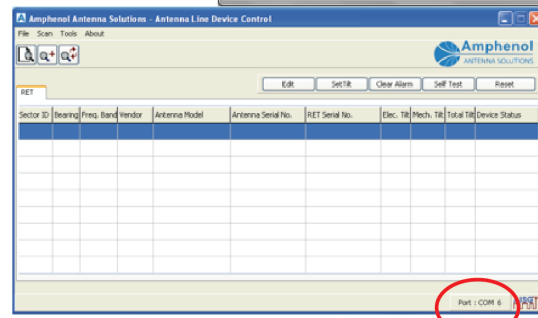
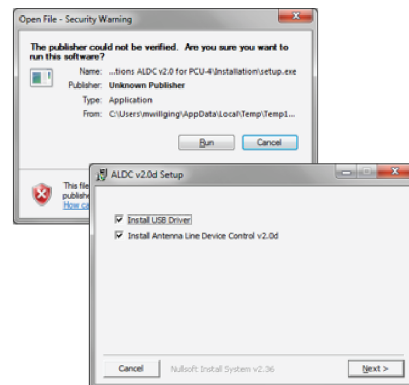
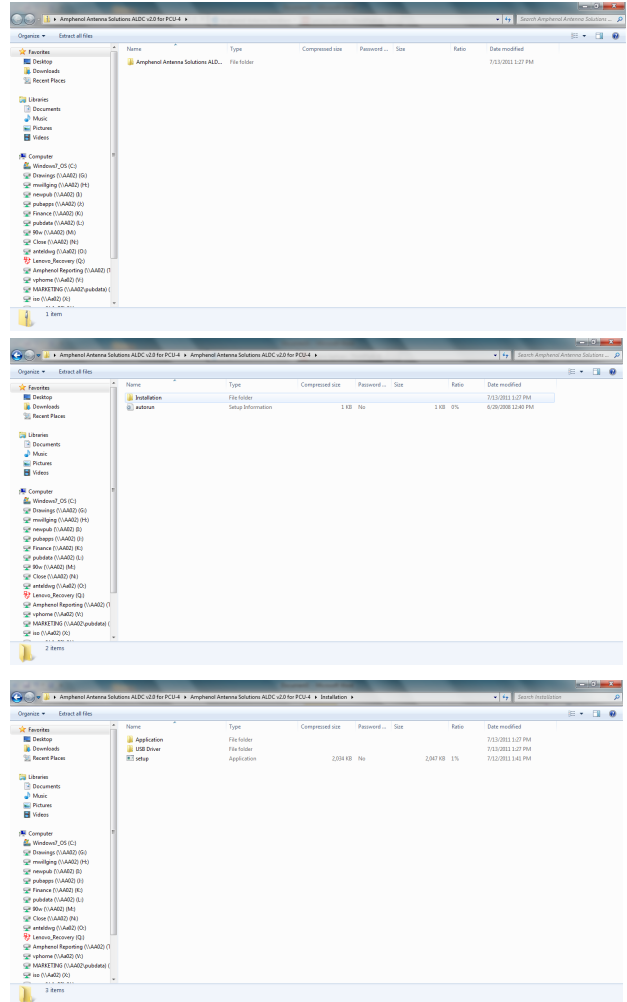

3. Launching the ALDC System Software

1. Click on the ALDC icon on the desktop to start the application. If you have installed the Start menu shortcut then you could also select Start > Programs > ALDC > ALDC v2.0. The screen displays the ALDC home screen.
2. Check the Port: COM number at the bottom of the home screen. Any number other than zero (0) means the USB cable is connected and detected by the system.
3. If the number is 0, the system is not properly connected. Either the USB cable is not connected with the adapter or the USB connection is not detected by the MS Windows system. In the latter case, please reconnect the cable and launch the system again.
4. Click on the **About** menu to determine the software version that was loaded into your installation CD.

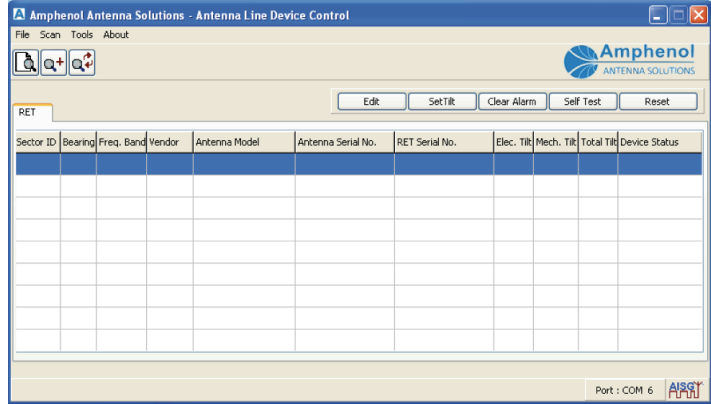

4. System Configuration

This section contains information about changing the system and adapter settings.

System Settings

The system settings determine how many bit-mask bytes will be used to scan the device and whether the scanning process will automatically assign bus addresses to devices found during a scan operation.

The default setting is [scan length] = 3

The scanning process will automatically assign bus addresses to the connected AISG devices.

A user will rarely need to change these default settings.

Changing System Settings

1. Select [Tools] from the menu.
2. Select [System Setting] from the Tools menu.
3. Decide whether to mark [Scan without Changing Address] and/or change the Scan Length value.

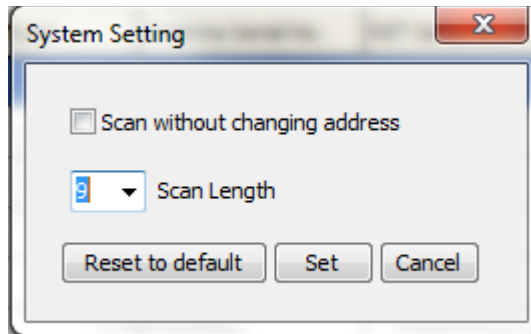
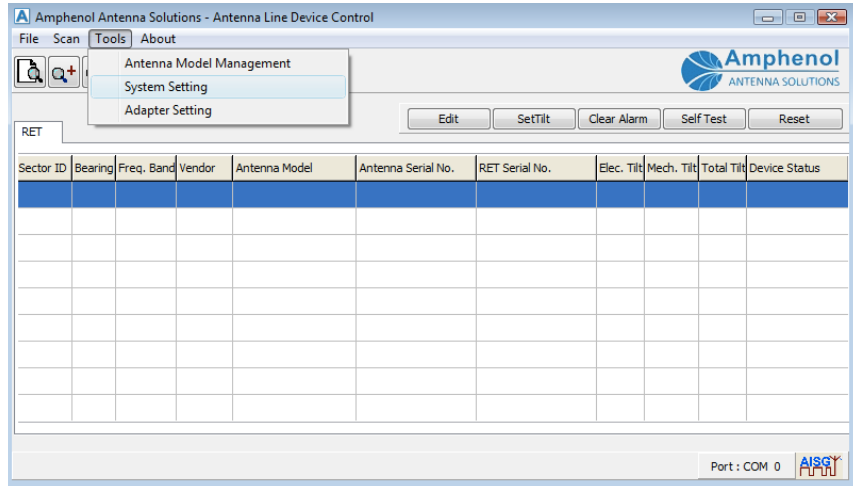

Scan without Changing Address

Purpose: Used to preserve the bus address of an AISG 1.1 device for trouble shooting.

NOT an applicable setting for the AISG 2 device.

By not checking the box, the system will automatically assign bus addresses to devices found during a scan operation.

Changing Scan Length Value

Purpose: Used to set the number of digits in the device serial number (from the far right) that the scan routine looks at during a scan operation.

MUST INCREASE the [Scan Length] value if multiple devices have serial numbers with the same last three far right digits.

NOTE This WILL increase the time required to complete a scan.

The default setting is three digits.

By leaving it on the default setting, you will reduce the time needed to complete the scan.

4. Click the [Set] button to apply changes made to the system.
The System Setting status window displays "Setting success."
5. Click the [OK] button to close the window.
6. If required click the [Reset to Default] button to rest these two setting back to the default value.

The System Setting status window displays "Load default setting success."

7. Click the [OK] button to close the window.
8. Return to the [System Setting] window; the system will save the new settings.

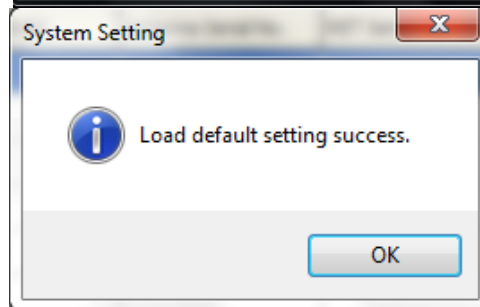
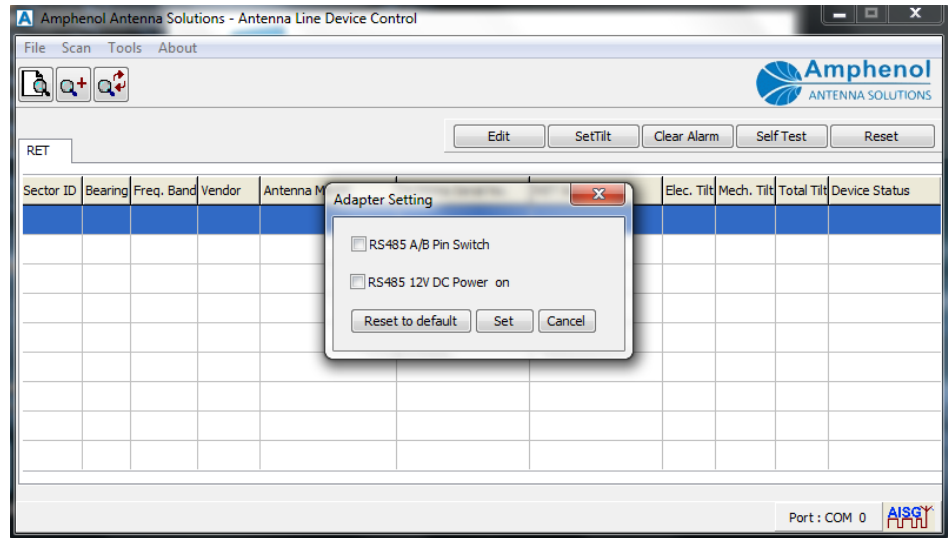
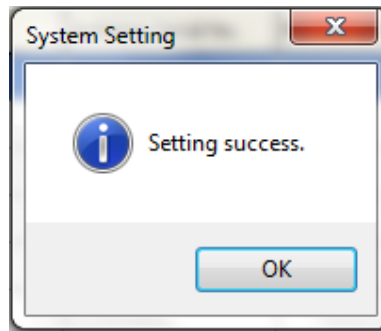

Adapter Settings

The adapter settings:

- Determine whether or not 12V DC is applied to pin 1 of the AISG connector.
- Determine the RS485 A/B pin settings for the adapter.

Once again, it is rare that a user should ever have to adjust these values.

Changing Adapter Settings

1. Select [Tools] from the menu.
2. Select [Adapter Setting] from the Tools menu.
3. Check either [RS 485 A/B Pin Switch] or [RS485 12V Power On].

Changing Adapter Settings, cont.

Option	Constraint/Limit
RS485 A/B Pin Switch	<p>Check the checkbox to switch the RS485 A/B pin of the adapter.</p> <p>Note The RS485 A/B pin polarity specification has not been uniformly interpreted by vendors that produce AISG-compliant hardware.</p> <p>Workaround: These vendors offered a short section of AISG cable to mechanically change the RS485 A/B pin polarity.</p> <p>Amphenol Resolution: The Amphenol Antenna Solutions PCU-4 provides the ability to electronically switch the pin polarity when required.</p>
RS485 12V Power On	<p>12V DC is turned on if the checkbox is checked.</p> <p>Note: The PCU-4 always applies 24V DC to pin 6. If this box is checked, then 12V DC will also be applied to pin 1.</p>

4. Click the [Set] button to apply changes made to the system.
The System Setting status window displays "Setting success."
5. Click the [OK] button to close the window.
6. If required, click the [Reset to default] button to reset the two adapter setting to the default values.
7. The screen displays **Load default setting success**. Click the [OK] button to close the message window.

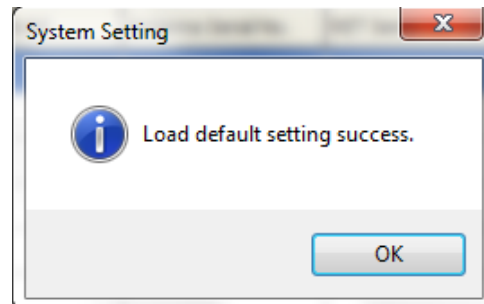
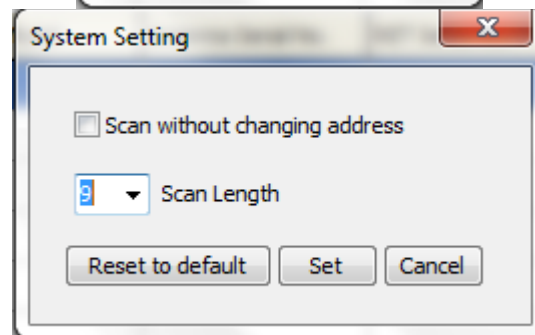
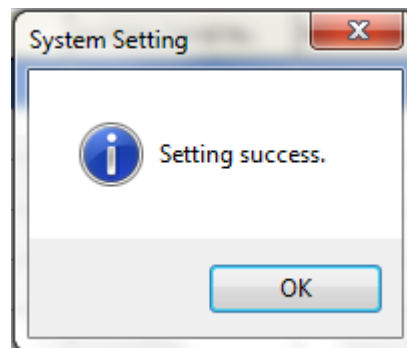

5. Using the ALDC System Software

Device Scan

The scan function will interrogate the AISG bus and display all AISG devices found.

- RET device types will display on the RET panel.
- TMA device types will display on the TMA panel.

Initiating the Scan Function

1. To initiate the scan function, either click on the scan device icon  in the tool bar or select Scan > Scan Device from the main menu. The screen displays a verification window.
2. Click [OK] to begin the scanning process.

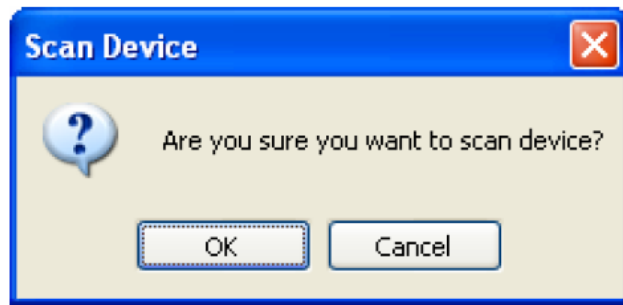

During the Scanning Process

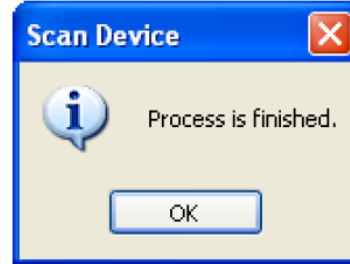
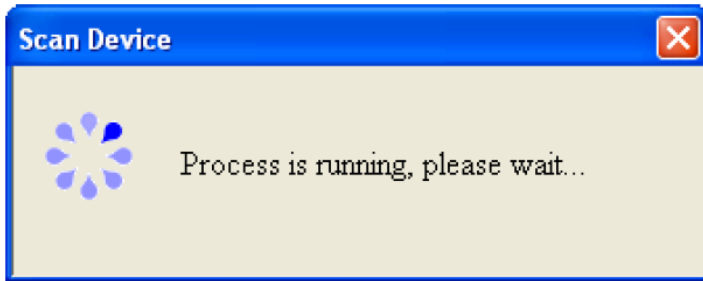

Check For:

- The Tx and Rx LEDs should flash on and off to indicate data transmission in both directions.
- Check to make sure that the RS485 A/B switch is set correctly. See Section 4, Changing Adapter Settings, pg 12.

Troubleshooting

Problem	Solution
The Tx LED does not illuminate.	Check all power and cable connections between the PCU-4 and the laptop computer
The Rx LED does not illuminate.	Check the cable connections between the PCU-4 and AISG devices.

Scan Results—RET

- The ALDC device status window displays all found RET devices.
- RET devices are automatically sorted by Sector ID.

Sector ID	Bearing	Freq. Band	Vendor	Antenna Model	Antenna Serial No.	RET Serial No.	Elec. Tilt	Mech. Tilt	Total Tilt	Device Status
alph	270	800/1800/1	Amphenol	HTXCW631518R000_H	908735	/RETEH/110711/547	2.2	0.0	2.2	OK
alph	270	800/1800/1	Amphenol	HTXCW631518R000_L	908735	/RETEH/110711/552	2.3	0.0	2.3	OK
beta	0	1800/1900	Amphenol	W65-13-R010	907560	/RETEH/110711/548	0.0	0.0	0.0	OK
gam	0	800	Amphenol	HTXC6318R000	890723	/RETEH/110711/551	0.0	0.0	0.0	OK

Device Name	Description/Constraint
Sector ID	Sector ID
Bearing	Antenna bearing in the range of 0-359 degrees
Freq. Band	Current applied frequency band(s)
Vendor	Vendor Name
Antenna Model	Antenna model name
Antenna Serial No.	Antenna serial number
RET Serial No.	AISG RET device serial number
Elec. Tilt	Current electrical tilt value
Mech. Tilt	Current mechanical tilt value
Total Tilt	Sum of mechanical tilt and electrical tilt
Device Status	“OK” or device alarm messages

Scan Results—TMA

- The ALDC device status window displays all found TMA devices.
- TMA devices are automatically sorted by Sector ID.

Sector ID	Freq. Band	Vendor	Antenna Model	Antenna Serial No.	TMA Model	TMA Serial No.	Current Gain	Mode	Device Status
B		Jaybeam	W65-13-A010	2008014103	TTA-LM01RH	TX:4074000969PORT0	12	Normal	OK
B		Jaybeam	W65-13-A010	2008014103	TTA-LM01RH	TX:4074000969PORT1	12	Normal	OK

Column Name	Description/Constraint
Sector ID	Sector ID
Freq. Band	Current applied frequency band(s)
Vendor	Vendor name
Antenna Model	Antenna model name
Antenna Serial No.	Antenna serial number
TMA Model	TMA model name
TMA Serial No.	TMA serial number
Current Gain	Current gain value
Mode	TMA gain mode: "Bypass" or "Normal"
Device Status	"OK" or device alarm messages
Sector ID	Sector ID

Add a Device

The Add a Device function is used to add a specific AISG device to the ALDC display list if that device cannot be found through the normal scan process.

Initiating the Add a Device Function

1. Click on the scan device icon  in the tool bar,
or
select Scan > Add Device from the main menu. The screen displays the Add Device dialog box.
2. Enter the Serial Number of the device you would like to add.
NOTE: This field is case sensitive!

For more about the device Serial Number, see the Additional Information section below.

3. Enter the Vendor Code if desired—this field is optional.
4. Click the [Add] button to add the device to the ALDC display list. The screen displays a process window until the process is finished.
5. Click the [OK] button to close the message window. The ALDC display list has just been updated with this device.

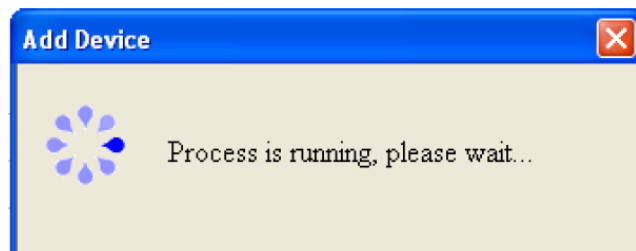
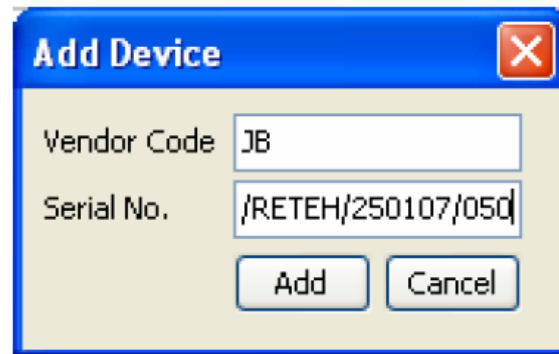

Additional Information about the Serial Number

According to the AISG standard, each device must be assigned a unique identification number. “Unique ID Number” is defined as the vendor code followed by a device serial number.

Amphenol Antenna Solutions displays one of two “Unique IDs” on each RET product shipped. This code can either be:

- JB (for Jaybeam Wireless)
- AI (for Amphenol Antenna Solutions)

Example: Jaybeam Wireless Antenna

- Unique ID = JB/RETEH/080508/114
- Vendor Code = JB
- Serial Code = /RETEH/080508/114



Refresh

The Refresh function is used to retrieve the latest device information for the devices displayed on the device list.

Initiating the Refresh Process

1. Click on the scan device icon  in the tool bar,
or
select Scan > Refresh Device from the main menu. The screen displays the Add Device dialog box.
2. The screen displays a process window until the process is finished.
3. Click the [OK] button to close the message window.

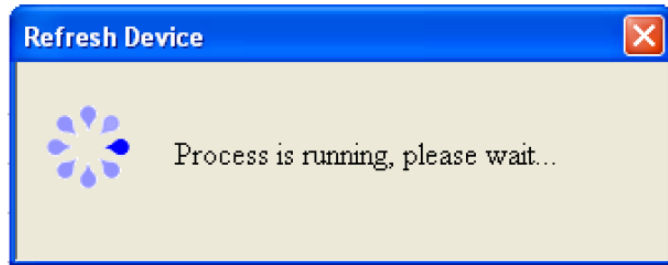

Tool Bar Commands

Commonly used commands for each device type are displayed at the top of each panel.

1. Click on a line to select a device. The line will change to a highlighted color.
2. Click on a command button:
 - Set Tilt
 - Clear Alarm
 - Self Test
 - Reset

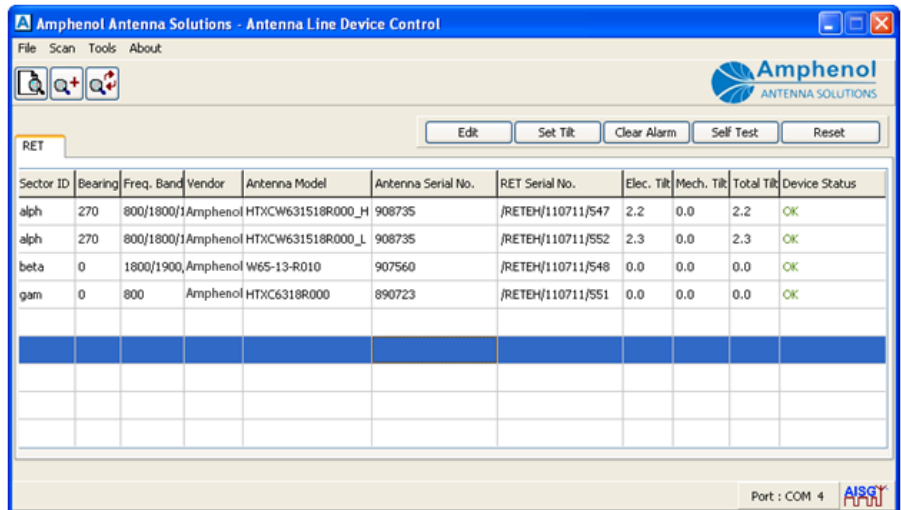

Set Tilt

1. Click the [Set Tilt] button on the tool bar. The screen displays the Set Tilt dialog box.
2. Change the Current Tilt value and then click the [Set Tilt] button to initiate the process.
3. The Set Tilt status window displays that the new electrical tilt value has been applied successfully.
4. Click the [OK] button to close the message window.

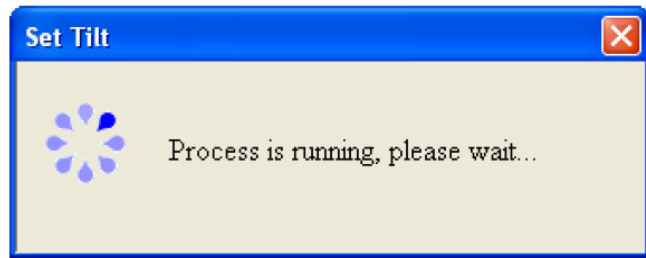
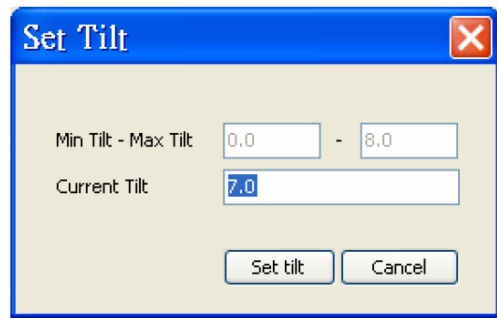

Clear Alarms

1. Click the [Clear Alarm] button on the tool bar to clear all open alarms on the system. The screen displays the Clear Alarms status window.
2. The screen displays "Process is finished" when the alarms are cleared. Click the [OK] button to close the message window.

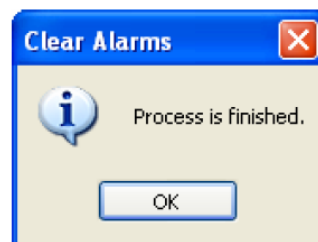
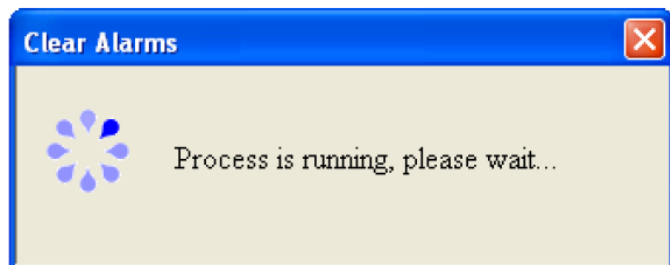

Self Test

This function will:

- perform a self test operation on the selected device
- report the outcome of that test

Using the Self Test Function

1. Click the [Self Test] button on the tool bar. This will initiate the self test process.
2. The screen displays a message when the self test is complete. Click the [OK] button to close the message window.

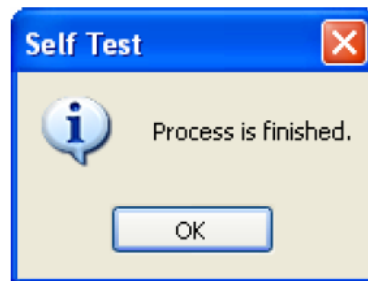
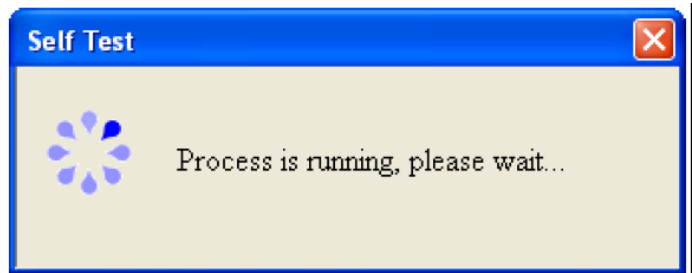

Reset Software

1. Click the [Reset] button on the tool bar. This will initiate the process. The screen displays a Reset Software progress window.
2. The screen displays a message when the software settings have been reset. Click the [OK] button to close the message window.

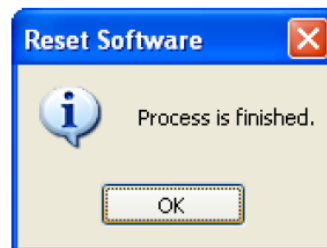
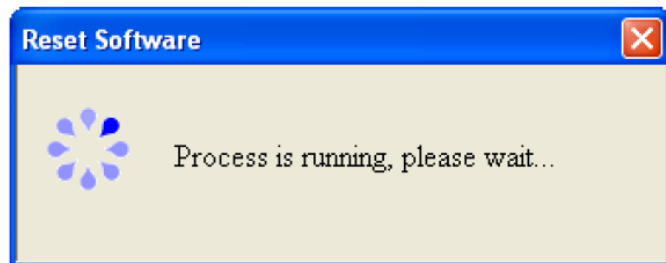

RET Detail Settings

You can edit device information using the ALDC software. To display the detailed data for the selected device, click the [EDIT] button on the tool bar menu OR double-click on the highlighted row for the device. The screen displays the RET Detail Setting.

Antenna Installation Data

Column Name	Description/Constraint
Sector ID	Sector ID
Site ID	Base station site ID
Installer's ID	Installer's ID
Installation Date	mmddyy format
Bearing	Antenna bearing in the range of 0-359 degrees
Mechanical Tilt	Installed mechanical tilt in degrees
Antenna Serial No.	Antenna serial number (may already be factory programmed)

Changing Installation Information

1. Type the new data in the appropriate field(s).
2. Check the box(s) beside the field(s) that you would like to update.

NOTE Only the field with a check in the checkbox will be uploaded to the RET. This is intended to prevent accidental changes.

3. Click the [Save Selected] button to upload the revised information to the RET.

Antenna Model Data

Column Name	Description/Constraint
Antenna Model	<p>If you cannot find a proper antenna model for the RET, refer to “Add an Antenna Model” (pg #) for how to add your antenna model</p> <p>WARNING: Changing the antenna model will upload a new configuration file to the RET device. DO NOT change the factor programmed antenna model name unless you are certain you know how to do so correctly. If uncertain, contact Amphenol Antenna Solutions technical support before changing this field.</p>
Frequency Band	Frequency band(s) used by the antenna
Beam Width	<p>Beamwidth for each band in frequency order.</p> <p>Split by and/or displayed in order according to Frequency Band</p>
Antenna Gain	<p>Gain for each band in frequency order</p> <p>Split by and/or displayed in order according to Frequency Band</p>

Changing the Antenna Model

It is only appropriate to upload a new antenna model to the RET device in the following circumstances:

- When transferring a RET unit from one antenna model to a different antenna model
 - NOTE** For external RET units, make sure that the RET electrical tilt and the antenna electrical tilt (as indicated by the dip stick) are set to the same setting before mechanically attaching the RET to the antenna.
- When upgrading the configuration file in the RET to a new release
 - NOTE** It is rare that a new configuration file is required for an Amphenol Antenna Solutions RET device. Only upload a new configuration file when instructed to do so by technical support.

Uploading a New Configuration File to a RET

- Select the antenna model from the drop-down list under the Antenna Model field.

NOTE If the desired antenna model is not found, refer to the “Antenna Model Management” section (pg 31) to learn how to upload the appropriate configuration data

- Click the Antenna Model checkbox.

The screenshot shows the 'RET Detail Setting' window. At the top, there are buttons for 'Calibrate', 'Clear Alarm', 'Self Test', 'Reset', and 'Download Software'. The 'Antenna Data' section includes several fields: Sector ID (B), Site ID (LA-100), Installer ID (TEB), Installation Date (122008), Bearing (120), and Mechanical Tilt (0.0). There are checkboxes for 'Antenna Model', 'Antenna Serial No.', 'Frequency Band', 'Beam Width (split by /)', and 'Antenna Gain (split by /)'. The 'Antenna Model' dropdown menu is open, showing a list of models including W65-13-R010, W65-19-R06, W65-13-R010, W65-19-R28, WB3X072X18R00, WBX018X20R050, and WBX033X14R050. A 'Sel' button is next to the dropdown, and a 'Save Selected' button is at the bottom right of the dropdown list. The 'ALS6 V1.x RET (address=1)' section contains fields for Status (OK), Vendor (Jaybeam), RET Model Name (RETU-EA01), RET Hardware Version (JBW-02), RET Serial No. (RETEH/250107/050), RET Software Version (JB4.01D), Min Tilt - Max Tilt (0.0 - 10.0), and Current Tilt (2.0). There are 'Set tilt' and 'Get tilt' buttons for the Current Tilt field, and a 'Close' button at the bottom right.

- Click the Save Selected button. The screen displays a Save Device Data confirmation dialog box.
- Click the [OK] button. The application initiates the process to upload a new configuration file to the RET device.

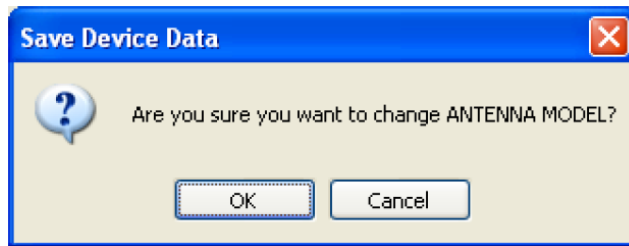

- The screen displays a status window; the new model data has been saved.
- Click the [OK] button to close this window.

NOTE Beamwidth and Gain do not automatically update when a new configuration file is uploaded to an Amphenol Antenna Solutions RET device.

- Refer to the antenna datasheet and manually update these fields if they are no longer correct.

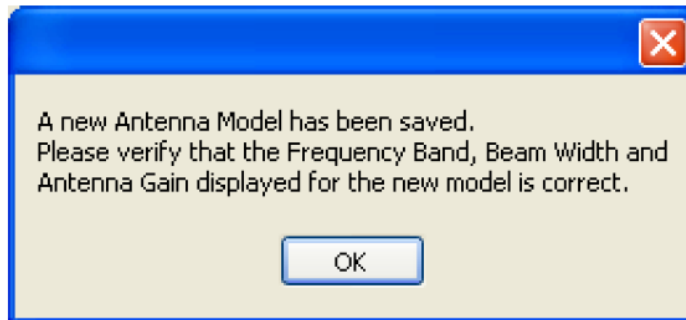

NOTE Beamwidth and Gain are "information only" data fields and do not have any impact on the actual performance of the antenna.

Changing the Frequency Band

- On The RET Detail Setting window, click on the [Sel] button. The screen displays available frequencies.
- Uncheck the checkbox of any frequency bands that do not apply to the current installation.
- Click the [Apply] button. The selected frequency band(s) will be refreshed back into [Frequency Band]. For each selected frequency band, if there are built-in values for beam width and gain in the system, these built-in values will be shown in the [Beam Width] and [Antenna Gain] fields; otherwise the field displays 0.0.

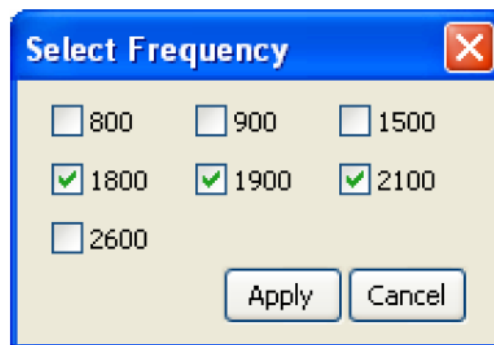

NOTE This display will look different for AISG v2.0 devices due to enhancements to the AISG specification related to available frequency band codes.

RET Model Data

Column Name	Description/Constraint
Status	“OK” or device alarm messages
Vendor	Vendor Name
RET Model Name	RET model name
RET Serial No.	RET serial number
RET Hardware Version	RET hardware version
RET Software Version	RET software version
Min Tilt – Max Tilt	Allowed electrical tilt range of the selected antenna model
Current Tilt	Tilt setting should be in the range of Min Tilt – Max Tilt

Set Tilt

This function provides a second location within the software to change the electrical tilt of an antenna.

1. Click the [Set Tilt] button on the RET Detail Setting tool bar. This will initiate the process. The screen displays a Reset Software progress window.
2. The screen displays a message when the software settings have been reset. Click the [OK] button to close the message window.

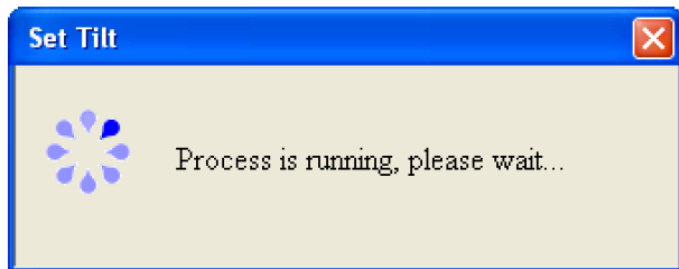

Get Tilt

This function interrogates the RET and then returns the current electrical tilt setting of an antenna.

Using the Get Tilt Function

1. Click the [Get Tilt] button on the tool bar.
2. The screen displays a message when the software settings have been reset. Click the [OK] button to close the message window.



Calibration

The [Calibrate] function initiates a calibration command to the selected device. The calibration command is required by some manufacturers to automatically “calibrate” the RET actuator to the antenna.

NOTE For most Amphenol Antenna Solutions devices, electronic calibration is not required.

- When a “calibrate” command is sent to the RET device it **WILL** change the tilt to Max Tilt then to Min Tilt and then return to the current tilt setting
- **Calibration is required for all F-BXA model antennas.**

Using the Calibration Function

1. Click the [Calibrate] button on the RET Detail Setting tool bar. This will initiate the process.
2. The screen displays a warning about site coverage that will change during calibration. Click the [OK] button to proceed.
3. The screen displays a Calibrate progress window.
4. The screen displays a message when the software settings have been reset. Click the [OK] button to close the message window.

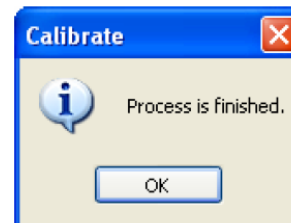
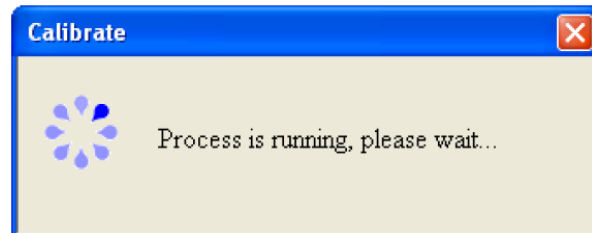
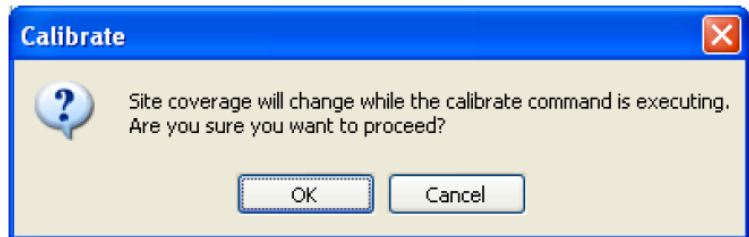

Download Software—RET and TMA

This function provides the ability to upload new firmware to selected AISG device. This feature can also be used to upload a small .hex file to selected Amphenol Antenna Solutions RET devices to change the operating mode from AISG v1.1 to AISG v2.0 and vice versa.

Downloading Software

1. Click the [Download Software] button on the RET Detail Setting tool bar. The screen displays a window where you can select the file to upload to the device.

NOTE The software program provided by the device vendor **MUST** have either .bin or .hex extension.

2. Select a software file and then click the [Open] button.

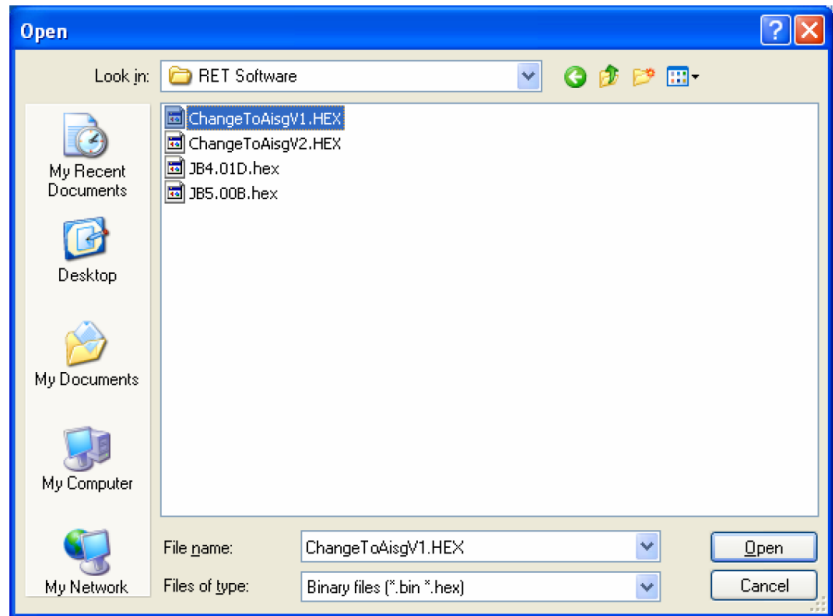

3. The screen displays a confirmation window. Click the [OK] button. The system downloads the software file.

NOTE The software download might take up to 20 minutes, depending on file size.

4. The screen displays a message when the software download is finished. Click the [OK] button to close the message window.

NOTE When switching the AISG operating mode of an Amphenol Antenna Solutions RET, it **may be necessary to re-scan** the bus in order for the software to establish proper communication with the device and to display the updated AISG version.

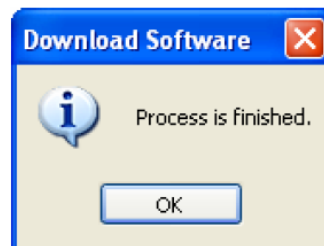
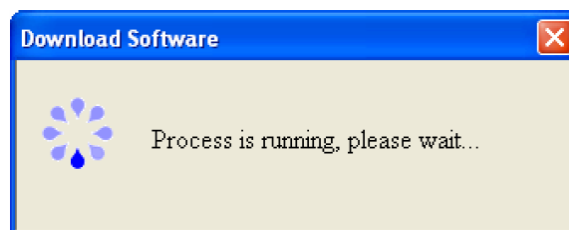
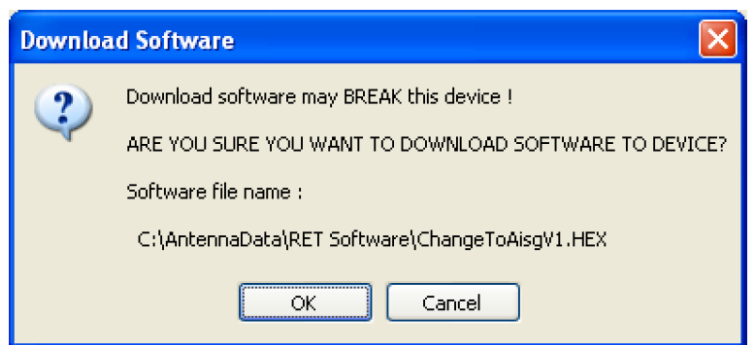

TMA Detail Settings

You can edit detail information for a TMA device using the ALDC software. To display the detailed data for the selected device, click the [EDIT] button on the tool bar menu OR double-click on the highlighted row for the device. The screen displays the TMA Detail Setting.

TMA Detail Setting

Clear Alarm Self Test Reset Download Software

Antenna Data

<input checked="" type="checkbox"/> Sector ID	B	<input type="checkbox"/> Antenna Model	W65-13-A010
<input type="checkbox"/> Site ID	LA-100	<input type="checkbox"/> Antenna Serial No.	2008014103
<input type="checkbox"/> Installer ID	TEB	<input type="checkbox"/> Frequency Band	
<input type="checkbox"/> Installation Date (mmddyy)	122008	<input type="checkbox"/> Beam Width (split by /)	0
<input type="checkbox"/> Bearing	240	<input type="checkbox"/> Antenna Gain (split by /)	0.0
<input type="checkbox"/> Mechanical Tilt	0.0		

Save Selected

AISG V1.x TMA (address=5)

Status	OK	Vendor	Jaybeam
TMA Model Name	TTA-UM01RH	TMA Hardware Version	G-Huawei
TMA Serial No.	TX4074000969PORT0	TMA Software Version	1.5.1-1.0
Min - Max Rx Freq. Band	1950 - 1964.9	Type	<input checked="" type="checkbox"/> Bypass <input type="checkbox"/> VSWR
Min - Max Tx Freq. Band	2110 - 2170	Mode	Normal
Min Gain - Max Gain	12 - 12	Current Gain	12
Gain Resolution	0		

Set Mode Get Mode Set Gain Get Gain Close

Antenna Installation Data (See “Antenna Installation Data”)

The antenna installation data fields for the TMA are identical to the fields previously described for the RET device.

Antenna Model Data (See “Antenna Model Data”)

The only difference between the RET antenna model data and TMA antenna model data is that the [Antenna Model] field **does not** upload an antenna configuration file to the device.

This field is a text-only field that is updated during installation to identify which serial number antenna the TMA is amplifying.

TMA Model Data

Column Name	Description/Constraint
Status	“OK” or device alarm messages
Vendor	Vendor Name
TMA Model Name	TMA model name
TMA Serial No.	TMA serial number
TMA Hardware Version	TMA hardware version
TMA Software Version	TMA software version
Min – Max Rx Freq. Band	Allowed receive frequency band range
Min – Max Tx Freq. Band	Allowed transmit frequency band rang
Min Gain – Max Gain	Allowed gain range of the TMA model
Gain Resolution	Gain increment from minimum gain to maximum gain.
Type	TMA type can be “Bypass” and/or “VSWR”
Mode	TMA mode can be “Bypass” or “Normal”
Current Gain	The value should be in the range of Min Gain – Max Gain

Set Mode

This function is to set the TMA. It can be either Bypass or Normal.

Using the Set Mode Function

1. Click the [Set Mode] button on the TMA Detail Setting window. This will apply the mode selected in the Mode field.
2. The screen displays a Set Mode progress window.
3. The screen displays a message when the Set Mode process is finished. Click the [OK] button to close the message window.

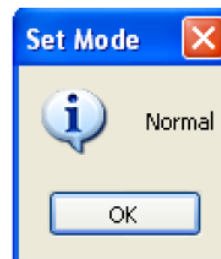
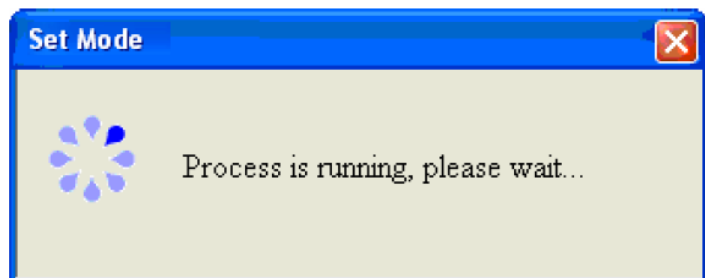

Get Mode

This function will interrogate the TMA device to determine the current TMA mode.

Using the Get Mode Function

1. Click the [Get Mode] button on the TMA Detail Setting window.
2. The screen displays the current TMA mode setting.
3. Click the [OK] button to close the message window.

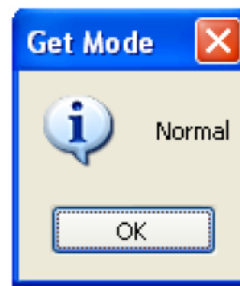

Set Gain

This function will set the TMA gain. TMA gain **MUST** fall between minimum and maximum gain values.

Using the Set Gain Function

1. Click the [Set Gain] button on the TMA Detail Setting window. The ALDC applies the gain value selected in the [Current Gain] field.
2. If this functionality is not supported by the device, the screen may display an "Unsupported Proc" or "Read Only" message to indicate the function is not supported, or displays a message that the gain value has been applied successfully.

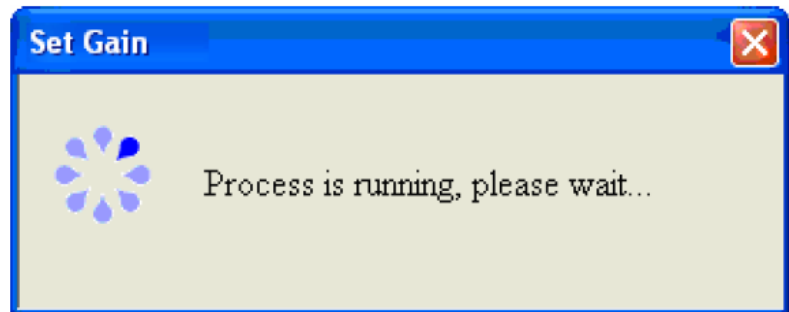

Get Gain

This function will interrogate the TMA device to determine the current TMA gain value.

Using the Get Gain Function

1. Click the [Get Gain] button on the TMA Detail Setting window.
2. The screen displays the current TMA gain value setting.
3. Click the [OK] button to close the message window.

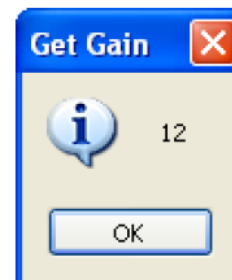

Site Report

The site report provides the ability to save a record of all device information at a site into a CSV format file. The default file name is "Report.csv." This file is a comma-delimited ASCII file that can be imported into EXCEL to allow easy sorting and formatting of the recorded site information.

Using the Site Report

1. Select File > Export Site Report from the main menu. The screen displays a "Save As" dialog box.
2. Create a folder for saving site logs.

Adopt a log naming convention to identify the site name and the date when the log was created.

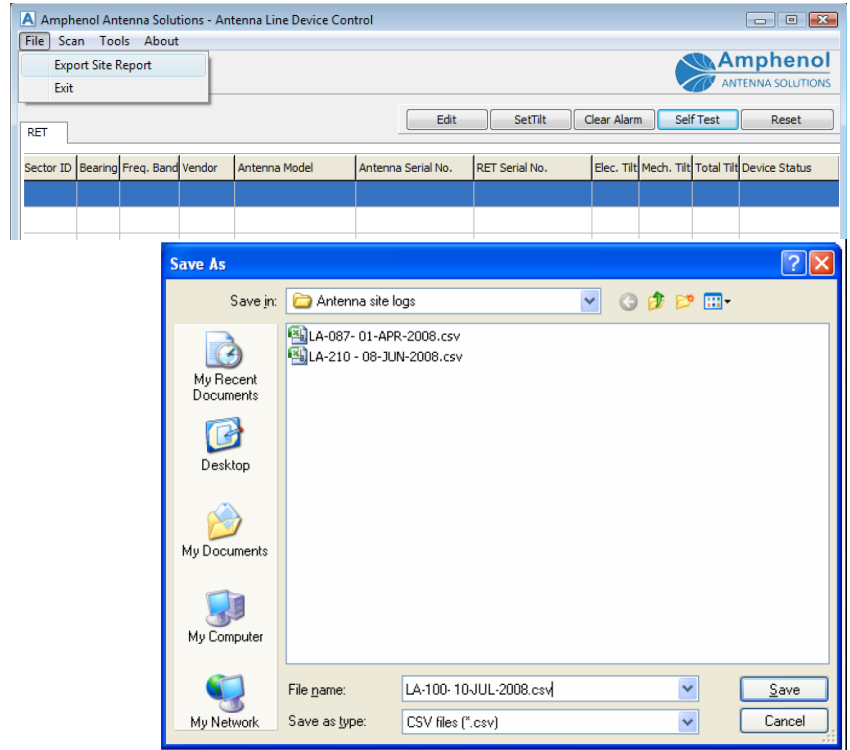

IMPORTANT:

- The CSV format log file can be easily imported into MS EXCEL or into MS WORD tables.
- All data fields associated with each device type are deposited in the log file.
- This file creates a record of the site configuration at the time the log file was created.

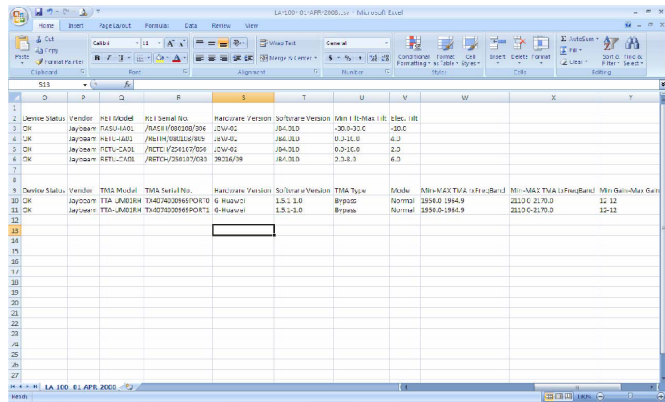
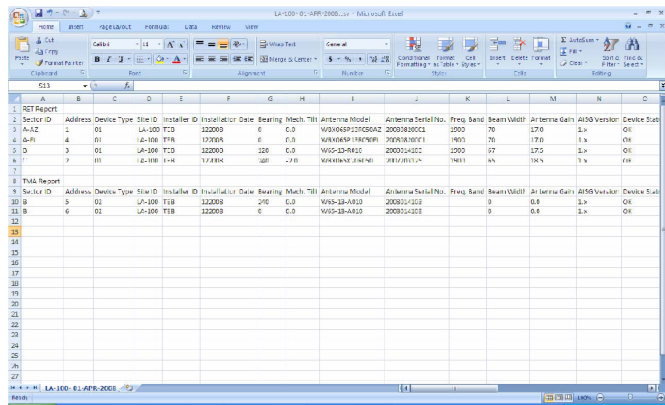

Antenna Model Management

The function of this section is to manage antenna configuration files that are loaded into the ALDC application software.

Antenna configuration files provide a “look-up” data table used by a RET actuator to correlate mechanical rotation or linear translation of the actuator to electrical tilt of the antenna beam. RET configuration file format and contents are specific to each antenna vendor and are unique for each antenna model.

Uploading Antenna Configuration Files

Important!

The content of the [Antenna Model List] depends on what files you have previously loaded.

Initially, no files are loaded. Contact the antenna manufacturer to make sure you have the latest version.

1. Set-up a vendor name in the system
2. Provide a place to store that vendor's files—See “Adding a Vendor.”
3. Click [Antenna Model Management] under [Tools] on the menu bar
4. Accesses the window for managing antenna configuration files

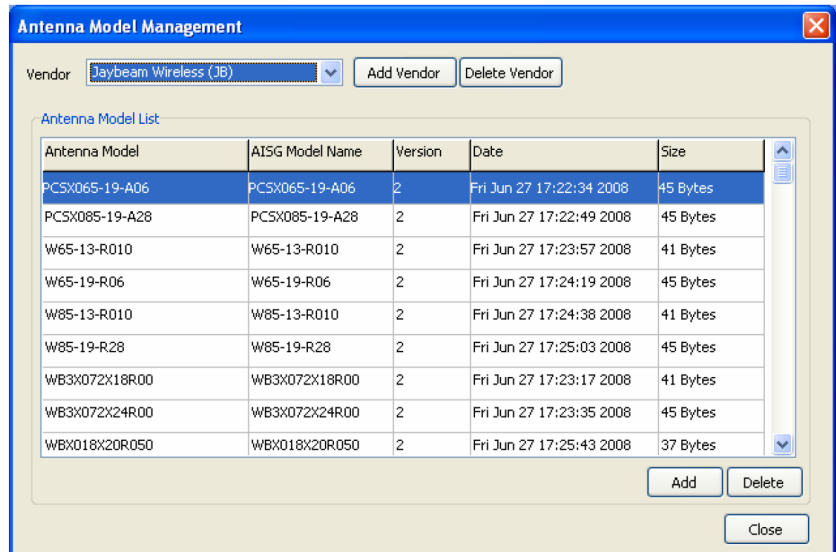
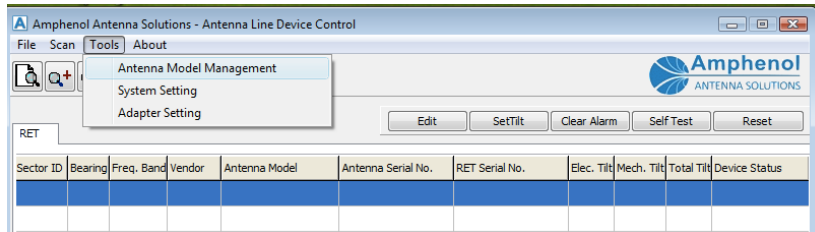

Add a Vendor

The vendor must exist in the [Vendor] list before you can upload configuration files for that vendor.

Adding a Vendor

1. Click the [Add Vendor] button on the Antenna Model Management window. The screen displays the Add Vendor dialog box.
2. Enter the two-letter AISG Vendor code for the vendor you would like to add.

NOTE Refer to the next page or www.AISG.org.uk for vendor codes.

3. Click the [Add] button. This action initiates the Add Vendor process.
4. The screen displays a status message when the process is complete. Click on the [OK] button to close the message window.

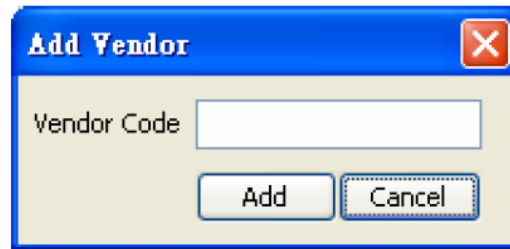

AISG Vendor Codes:

Vendor Code	Company Name	Vendor Code	Company Name
AA	Alcatel	LA	Powerwave Technologies Inc
AC	ADC, Inc	LG	Powerwave Technologies Inc
AD	Alan Dick and Co Ltd	LO	Lorch Microwave Inc
AE	ACE Technology Corporation	LU	Lucent Technologies
AF	Aerial Facilities Ltd	MA	Jaybeam Wireless
AI	Amphenol Antenna Solutions (formerly Amphenol	MD	Microdata Telecom Innovation AB
AM	ARIALCOM SA	MI	Mitec Inc
AN	Andrew Corporation	ML	Microlab/FXR
AR	Argus Technologies (Australia) Pty Ltd	MO	Motorola
AV	Avitec AB	MT	Mobile Antenna Technologies (Shenzhen)
AW	Antone Wireless Corp	MY	Sistemas Radiantes, F. Moyano, S.A.
AX	Axis Network Technology Ltd	NA	NEC ANTEN Ltd
BT	Bravo Tech Inc.	ND	Nihon Dengyo Kosaku Co Ltd
BW	Böke & Walterfang Ltd	NK	Nokia
CB	Comba Telecom	NN	Nortel Networks
CC	CSS Antenna Inc.	NT	Netop Technology
CE	C3EM SA	NX	NXP
CI	Communication Components Inc	PC	PCTEL, Inc.
CL	ClearComm Technologies, LLC	PO	Polyphaser Corp.
CM	Combilent A/S	PR	Prism Microwave LLC
CO	Comba Telecom	PW	PowerWave Technologies Inc
CS	Jaybeam Wireless	QU	Quintel Ltd
CT	Celletra, Inc	RA	Racal Antennas Ltd
CX	Cellmax Technologies	RC	Radio Components Sweden AB
DA	DAPA Systemes SA	RD	Radio Design Ltd
DB	Andrew Corporation	RE	Powerwave Technologies Inc
DK	Denki Kogyo Co Ltd	RF	RFS Inc
EB	Elektrobit Ltd	RK	R&K Company Ltd
EM	EMS Technologies, Inc	RM	RFM Wireless
ET	ETSA	RY	RYMSA SA
ER	Ericsson	SA	SPAA05
EY	Eyecom Technologies	SD	SDP Components Inc
FG	Wuhan Fingu Electoinc Co Ltd	SE	Selecrom SA
FI	Filtronic Ltd	SH	University of Sheffield (UK)
FO	Andrew Corporation	SM	Siemens AG
FR	Fractus SA	SI	Sigma Wireless Technology Ltd
FU	Furukawa Communications & Broadcasting Co Ltd	SP	Spinner GmbH
GN	Gamma Nu Inc	SQ	Signal Quest, Inc
GR	Grintek Antennas	SR	Guangzhou Sunrise Telecom Eqpt Co Ltd.
GT	Gemintek Corporation	SS	Sunsight Instruments LLC
HE	Xiamen Helios Telecom Equipment Manufacture Inc	ST	Stella Doradus Waterford Ltd
HG	High Gain Antenna Co	SU	Sunwave Communications Co Ltd
HI	Hitachi Cable Co Ltd	SW	Sunwave Tec
HH	HCS-HES Cabling Systems	TH	Racal Antennas Ltd
HS	Huber + Suhner	TN	Telnet Redes Inelligentes
HX	Wuhan Hongzin Telecoms Technologies	TR	Triasx Pty. Ltd,
IT	Innerton, Inc.	TT	Jiangsu JST Technologies (Nanjing) Co Ltd
JB	Jaybeam Wireless	TY	Tongyu Communications Equipment Co
HW	Huawei Technology Ltd	TX	TenXc Wireless Inc.
KA	Kathrein KG	UW	Unity Wireless Corporation
KL	K & L Microwave Inc	VX	Voxaura Technologies Inc
KM	KMW Ltd	XH	Xi'an Haitian Antenna Technologies Co Ltd

NOTE The existence of an assigned Vendor Code does not indicate that the company to which it was assigned is still manufacturing or trading under the name shown nor that is a member of AISG.

Delete a Vendor

IMPORTANT NOTE: Before deleting a vendor, you **HAVE** to make sure no model exists under this vendor

If there is a model stored under the selected vendor

- A warning message will appear
- The vendor **WILL NOT** be deleted

Deleting a Vendor

1. Select the vendor that you would like to delete from the [Vendor] list
2. Click the [Delete Vendor] button next to the [Vendor] list
3. Click [OK] to close the confirmation window.
4. Delete the selected vendor from the system
5. Refresh the [Vendor] list
6. Click [OK] to close the window that will appear to show that the process was a success.

Add an Antenna Model

This function will upload a configuration file from the selected vendor to the specific location in the PC.

NOTE The vendor **MUST** exist in the [Vendor] list before antenna models can be uploaded.

Adding an Antenna Model

1. Select a vendor from the [Vendor] list
2. Click the [Add] button below the Antenna Model list, which uploads a configuration file from that vendor

Column Name	Description/Constraint
Vendor Name	Vendor Name
Config File	File name with its full path should be provided Only a file less than 0.5 KB with extensions of .bin, .RETbin or .acf is allowed.
Antenna Model Name	Antenna model name NOTE The configuration file name will be used as the default model name that is allowed to be changed.
AISG Model Name	The model name will be stored in RET device. NOTE The maximum length of AISG model name is 15 characters.
Version	The antenna model configuration file version (optional)

3. Browse your computer to find the configuration file provided by your antenna vendor.

NOTE If it is an Amphenol Antenna Solutions .RETbin file that contains the Config. File version code as part of the file name, see step 5. If this is not the case, skip to step 6

4. Edit the Antenna Model Name and Version fields before selecting [Add] to document the version code to the appropriate location
5. **ONLY** if the Amphenol Antenna Solutions .RETbin file contains the Config. File version code as a part of the file name.
6. Click the [OK] button to close the message window that signifies success.

Delete an Antenna Model

This function will delete a selected antenna model from the system.

1. Click the [Delete] button, which will cause a confirmation window to appear
2. Click the [OK] button to delete the selected antenna model

Appendix A: Changing AISG Communications Mode

Amphenol Antenna Solutions RET units are designed to operate in either AISG v1.1 or AISG v2.0/3GPP communications mode.

Switching Between Communication Modes

A very small file must be sent to the RET using the “Download Software” feature of the primary controller.

Changing Communication Modes (Using the ALDC v2.0 Primary Control Software)

1. Locate Files

- a. Locate the folder “AISG Mode” containing the files:
“ChangeToAisgV1.hex”
OR
“ChangeToAisgV2.hex”

NOTE These files were provided with your software installation CD.

- b. Store these files in the same directory where the ALDC software is store

2. Verify the Current AISG Mode

A. Find the current AISG operating mode for a RET device by double-clicking on the device in the main menu or selecting the [Edit] tab.

NOTE The AISG mode is displayed in the location indicated in the picture.

3. Change the Communications Mode

- a. Click the [Download Software] button, which launches the window where you can select the file to upload the device.
- b. Select the file whose name matches the operation you would like to perform.
- c. Click the [Open] button after selecting the file, which will cause a confirmation window to appear
- d. Click the [OK] button to initiate the download process
- e. Click the [OK] button to close the message window that signals the process was a success.
- f. Verify that the communications mode was changed correctly
- g. Double-click on the device in the main menu or select the [Edit] button
- h. Verify that the new AISG mode is displayed

Appendix B: Remote Azimuth Steering (RAS)

Overview

Standard AISG-ES-RAS v2.1.0 was released by the Antenna Interface Standards Group (AISG) in December 2007 as an **optional** extension to AISGv2.0 to define procedures for controlling Remote Azimuth Steering (RAS) devices.

Unfortunately, this specification has the following practical limitations:

- RAS device types are not
 - Yet supported by many OEM primary controllers
 - Recognized by legacy AISGv1.1 controllers

In order to overcome these limitations Jaybeam Wireless has developed two-way adjustable (RET/RAS) antennas using the following internal device configuration:

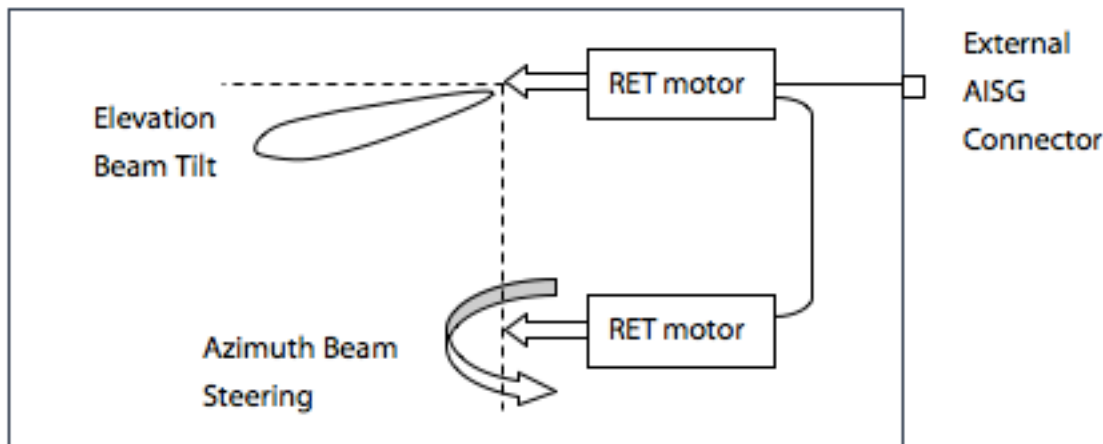

In this configuration two separate actuators are installed inside the antenna.

One actuator is used to control elevation beam tilt, while the other actuator is used to control azimuth beam steering. BOTH actuators are programmed as a "RET" device type according to the AISG standard.

This enables the antenna to be controlled using legacy AISGv1.1 controllers as well as the newer AISGv2.0 systems.

The only drawback to this approach is that care **MUST** be given during site set-up to clearly identify the function of each "RET" device found.

RAS Device Setup

NOTE To avoid confusion it is highly recommended that installers configure two-way adjustable antennas on the **ground** before installing the antennas at the top of the tower.

Scan the first antenna

1. Connect the AISG control cable from the PCU directly to the first antenna to be programmed.
2. Click the scan device icon on the tool bar or click [Scan Device] from in the [Scan] menu bar to start the ALDC software.
3. Click [OK] to close the verification screen that will appear.
4. Two RET device will be found. The first device will be the azimuth actuator and the other will be the elevation actuator.
5. Verify by looking at the "Model Name", which will include either "AZ" for Azimuth or "EL" for Elevation.

NOTE The "Antenna Serial No." for both actuators will be the same since they are both installed inside the same antenna.

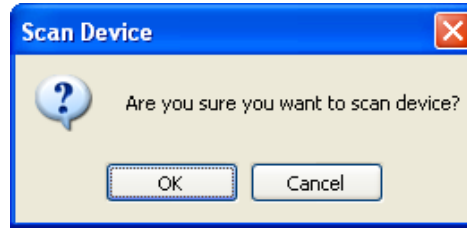

Sector ID	Bearing	Freq. Band	Vendor	Antenna Model	Antenna Serial No.	RET Serial No.	Elec. Tilt	Mech. Tilt	Total Tilt	Device Status
0		1800/1900	Jaybeam	WB06SP18R00AZ	2006315001	(RASIH)080512/035	0.0	0.0	0.0	OK
0		1800/1900	Jaybeam	WB06SP18R00EL	2006315001	(RETH)080512/036	2.0	0.0	2.0	OK

Configure Sector ID and Bearing

1. Double click on the first device to access the RET detail page.
2. Program the Sector ID and Bearing according to the following plan:
 - Sector ID has **no more than four** characters

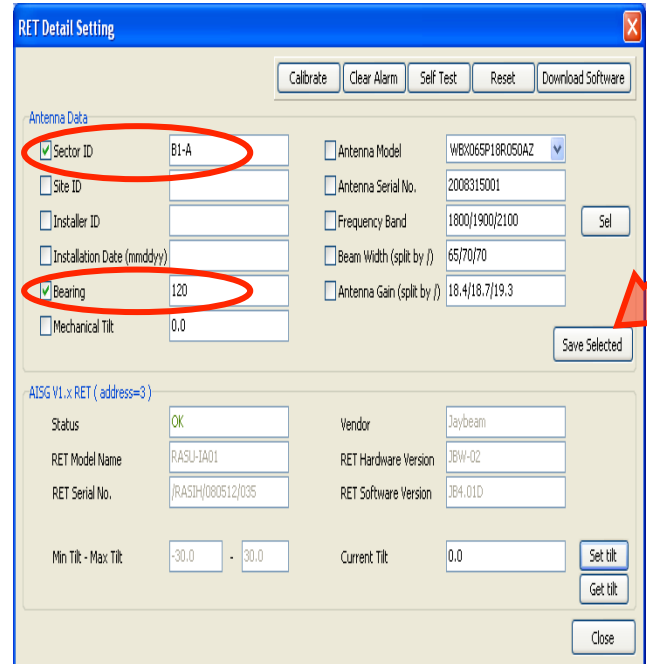
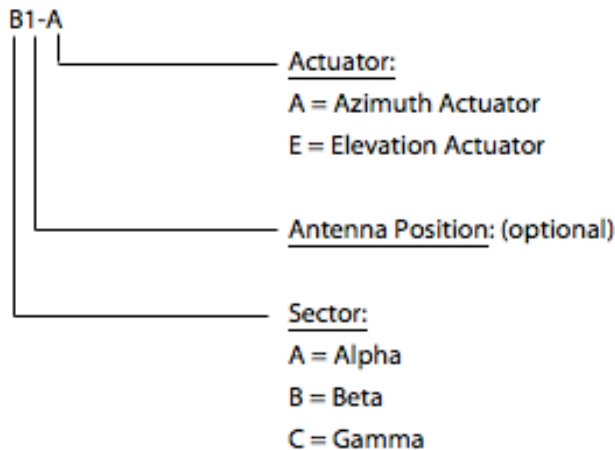

Configure Sector ID and Bearing, cont.

- Bearing (0-359)—Enter the **PLANNED mechanical pointing direction** of the antenna after installation expressed in degrees **East of True North (ETN)**

NOTE This is based on the site plan

3. Repeat steps 1 and 2 for the Elevation actuator.

NOTE Mark the Sector ID **ON** the antenna so that the installation crew will know where to install the antenna!

4. Repeat steps 1 and 2 for **ALL** antennas at this site.

5. Using the AISG control cables for this sites, connect **ALL** antennas together and scan, verifying:

- That all AISG cables are function correctly
- That the actuators have been programmed correctly

6. Install the antennas.

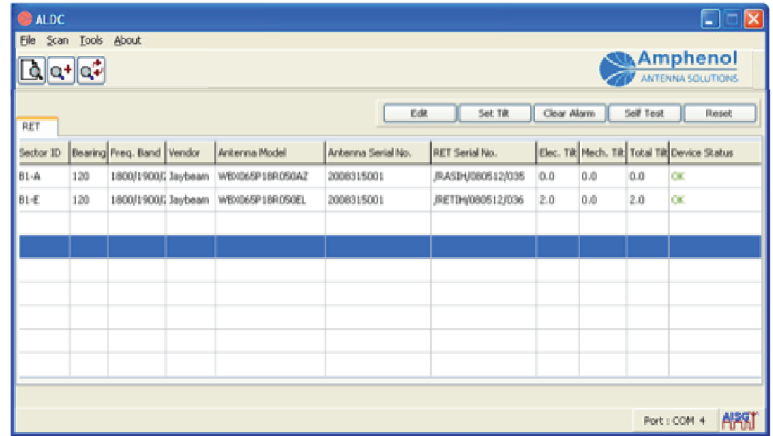

The screenshot shows the ALDC software interface with a table of antenna configurations. The table has the following columns: Sector ID, Bearing, Freq. Band, Vendor, Antenna Model, Antenna Serial No., RET Serial No., Elec. Tilt, Mech. Tilt, Total Tilt, and Device Status. Two rows are visible, both for Sector ID B1-E.

Sector ID	Bearing	Freq. Band	Vendor	Antenna Model	Antenna Serial No.	RET Serial No.	Elec. Tilt	Mech. Tilt	Total Tilt	Device Status
B1-A	120	1800/1900F	Jaybeam	WB065P18R050A2	2006315001	JRAS1H060512/035	0.0	0.0	0.0	OK
B1-E	120	1800/1900F	Jaybeam	WB065P18R050E1	2006315001	JRET1H060512/036	2.0	0.0	2.0	OK

The Antenna Azimuth Setting

The Electrical Tilt of each azimuth actuator is equivalent to the Azimuth Offset as defined by the AISG-ES-RAS v2.1.0 extension:

- “Azimuth Offset is equal to the angle, expressed in degrees, between the azimuth bearing of an antenna and the maximum of its main beam in the azimuth plane
 - A positive azimuth offset means that the antenna beam is directed to a compass heading numerically greater than the azimuth bearing.
 - An antenna has separate values for azimuth bearing and azimuth offset.
 - The azimuth bearing is fixed by the geometry of the installation.
 - The azimuth offset is remotely controllable and variable.”

Changing the Antenna Azimuth Setting

- Select the azimuth actuator of the antenna you would like to adjust.
- Select [Set Tilt] from the menu bar.
- Enter the number of degrees you would like to rotate the antenna beam, based on the view from above the antenna.
 - Positive is a clockwise rotation
 - Negative is a counter clockwise rotation
- Click the [Set tilt] button.

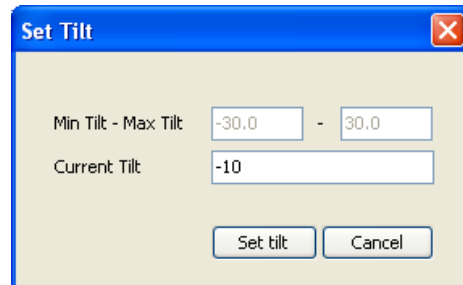

The 'Set Tilt' dialog box shows input fields for 'Min Tilt - Max Tilt' (set to -30.0 - 30.0) and 'Current Tilt' (set to -10). There are 'Set tilt' and 'Cancel' buttons at the bottom.

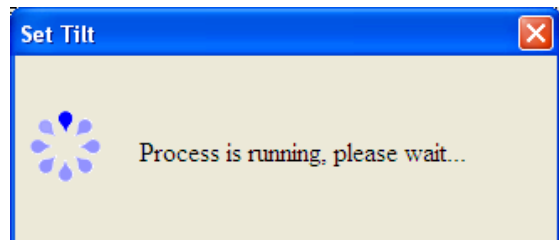

Changing the Antenna Azimuth Setting

5. A message will appear notifying you that the process was successful. Click the [OK] button to close the message window.
6. The Azimuth offset will now appear on the display in the “Elec. Tilt” column indicating the change in the beam direction.

True beam direction can be determined by adding the “Bearing” to the “Elec. Tilt.”

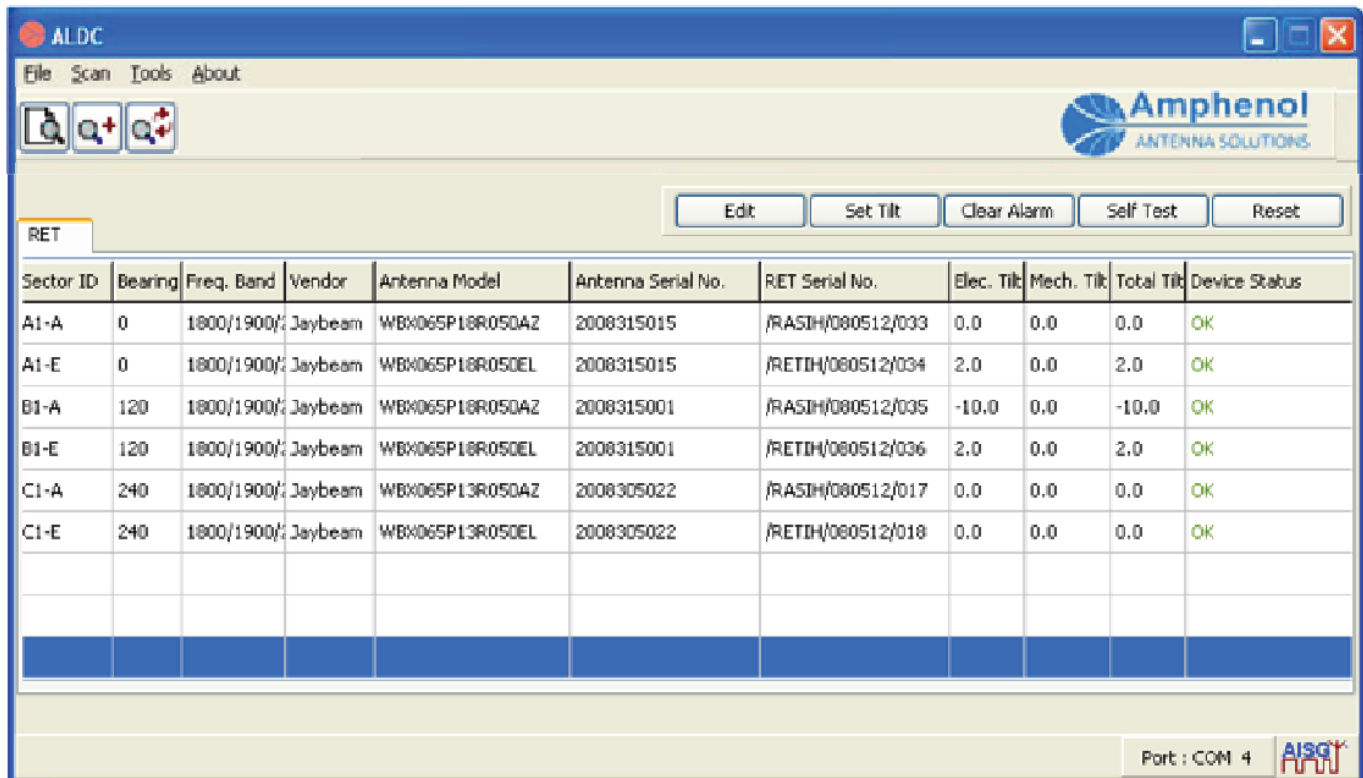
The screenshot shows the ALDC software interface. At the top, there is a menu bar with "File", "Scan", "Tools", and "About". Below the menu bar are three icons: a magnifying glass, a magnifying glass with a plus sign, and a magnifying glass with a plus sign and a red cross. The Amphenol logo and "ANTENNA SOLUTIONS" are in the top right. Below the logo is a toolbar with buttons for "Edit", "Set Tilt", "Clear Alarm", "Self Test", and "Reset". A tab labeled "RET" is selected. The main area contains a table with the following data:

Sector ID	Bearing	Freq. Band	Vendor	Antenna Model	Antenna Serial No.	RET Serial No.	Elec. Tilt	Mech. Tilt	Total Tilt	Device Status
A1-A	0	1800/1900/	Jaybeam	WBX065P18R050AZ	2008315015	/RASIH/080512/033	0.0	0.0	0.0	OK
A1-E	0	1800/1900/	Jaybeam	WBX065P18R050EL	2008315015	/RETIH/080512/034	2.0	0.0	2.0	OK
B1-A	120	1800/1900/	Jaybeam	WBX065P18R050AZ	2008315001	/RASIH/080512/035	-10.0	0.0	-10.0	OK
B1-E	120	1800/1900/	Jaybeam	WBX065P18R050EL	2008315001	/RETIH/080512/036	2.0	0.0	2.0	OK
C1-A	240	1800/1900/	Jaybeam	WBX065P13R050AZ	2008305022	/RASIH/080512/017	0.0	0.0	0.0	OK
C1-E	240	1800/1900/	Jaybeam	WBX065P13R050EL	2008305022	/RETIH/080512/018	0.0	0.0	0.0	OK

At the bottom right, there is a status bar showing "Port : COM 4" and the AISQ logo.

Example

The azimuth pointing direction of the antenna beam equals:

$$120 \text{ degrees} + (-10 \text{ degrees}) = 110 \text{ degrees}$$



Amphenol Antenna Solutions

1300 Capital Drive

Rockford, Illinois 61109 USA

+1 815.399.0001

www.amphenol-antennas.com