

FLT-187-JJ

3500 MHz | Band Pass Filter | Twin Unit

- 3500 Band Pass Filter with rejection radar bands of <3.4 GHz
- With DC/AISG bypass configurations
- Suitable for indoor and outdoor applications
- Can be mounted on pole or wall

**NO
IMAGE
AVAILABLE**
**COMING
SOON**

Electrical Characteristics		
Pass Band Frequency	3400-3600 MHz	
Insertion Loss	< 0.8 dB; 0.4 typical	
Stop Band Attenuation (3300-3390 MHz)	> 36 dB	
VSWR	< 1.25	
IM3 (2x43 dBm)	< -117 dBm	
Input Power	< 200 W	
DC/AISG Transparency	Bypass; 2500 mA (max)	
Environmental Characteristics		
Operating Temperature Range	-40° to +65° C (-40° to +149° F)	
Application	Indoor / Outdoor	
Ingress Protection	IP67	
Lightning Protection	10 kA 8/20 μs	
Mechanical Characteristics		
Connectors	7/16-DIN Female (Long Neck)	
Dimensions - without connectors or brackets (Length x Width x Depth)	280 x 220 x 84 mm	11.0 x 8.7 x 3.3 in
Weight	4.5 kg	9.9 lbs
Packing Dimensions (L x W x D)	460 x 313 x 230 mm	18.1 x 12.3 x 9.1 in
Mounting Characteristics		
Pole / Wall Bracket	Attach to pole diameter Ø40-Ø135 mm (Ø1.57-Ø5.3 in) or wall mount	

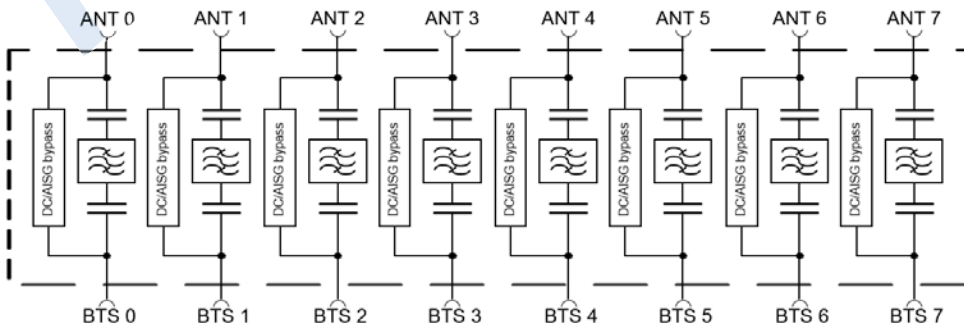

Quoted performance parameters are provided to offer typical, peak or range values only and may vary as a result of normal testing, manufacturing and operational conditions. Extreme operational conditions and/or stress on structural supports is beyond our control. Such conditions may result in damage to this product. Improvements to products may be made without notice.